

Data delivery – Schemas – Processing feedback 2024

Incomes Register Unit

Version history

Version	Date	Description
1.0	03/06/2024	Document for 2024 published.
		Corrected Record owner's record reference (DeliveryId) data in the data group Details of the received record (DeliveryData) to be voluntary (V).



CONTENTS

1	General	4
1.1	Schema	4
1.2	Character set	4
1.3	Dates and times.....	5
1.4	Document reading instructions.....	5
2	Processing feedback (StatusResponseFromIR)	7
2.1	Details of the received record (DeliveryData).....	9
2.2	Processing feedback data (StatusResponse).....	11
2.3	Approved items (ValidItems).....	13
2.4	Rejected items (InvalidItems).....	17
2.5	Message-level errors (MessageErrors).....	21
2.6	Record-level errors (DeliveryErrors)	22



1 GENERAL

1.1 Schema

Processing feedback is distributed from the Incomes Register using the **StatusResponseFromIR** schema.

The namespaces of the schema are as follows:

File name	Prefix	Namespace
	xmlns:xs	http://www.w3.org/2001/XMLSchema
StatusResponseFromIR.xsd	xmlns:srfir	http://www.tulorekisteri.fi/2017/1/StatusResponseFromIR
StatusMessageTypes.xsd	xmlns:smt	http://www.tulorekisteri.fi/2017/1/StatusMessageTypes
IRCommonTypes.xsd	xmlns:irct	http://www.tulorekisteri.fi/2017/1/IRCommonTypes
xmldsig-core-schema.xsd	xmlns:ds	http://www.w3.org/2000/09/xmldsig#

Empty elements are not allowed in the messages. If an element receives no value, the element is left out of the message entirely. Empty character strings are also not allowed, i.e., the minimum length of all values is 1.

1.2 Character set

The schemas of the Incomes Register use UTF-8, which is the default character set of XML. The file must not contain the Byte Order Mark (BOM) character.

The following table presents the requirements for the conversion of special characters appearing in messages.

Character	Description	Presentation format as an entity
&	ampersand	& conversion is mandatory
<	less than	< conversion is mandatory
>	greater than	> conversion is not mandatory, but conforms with best practices
'	apostrophe	' conversion is not mandatory, but conforms with best practices
"	quotation mark	" conversion is not mandatory, but conforms with best practices
--	double hyphen	This character must not appear in an XML file
/*	slash asterisk	This character must not appear in an XML file
&#	ampersand hash	This character must not appear in an XML file

A limited character set is allowed for **reference data**. The allowed characters for the reference data listed below are the numbers 0-9, the letters a-z and A-Z and the symbols " _ " and "-".

- Record owner's record reference (DeliveryId)
- Payer's report reference (ReportId)
- Subscriber's primary subscription reference (MainSubscriptionId)
- Subscriber's secondary subscription reference (SubscriptionId)
- Sender's message reference (MessageId)

In the following data items, upper and lowercase characters are significant:

- Country codes in all data groups (for example, "DE" is interpreted to be a different code than "De").
- Customer IDs in all data groups (for example, "150172-999H" is interpreted to be a different ID than "150172-999h").

1.3 Dates and times

Dates (data type xs:date) must not include time zone information. Example of a date:

```
<StartDate>2017-05-11</StartDate>
```

Data elements containing times of day (data types xs:dateTime and xs:time) must include the time zone.

Example in the Finnish time zone (standard time, UTC+2):

```
<Timestamp>2017-05-11T08:00:00+02:00</Timestamp>
<Time>08:00:00+02:00</Time>
```

Example in UTC time (UTC+0):

```
<Timestamp>2017-05-11T6:00:00Z</Timestamp>
<Time>06:00:00Z</Time>
```

1.4 Document reading instructions

In the document diagrams, the 0 .. ∞ marking in the bottom right-hand corner of an element means that the element may appear several times, or not at all. The 1 .. ∞ marking means that the element may appear several times, but must always appear at least once. The mandatory elements are highlighted with a solid border line and voluntary elements with a dashed border line.

In the document tables, the mandatory or voluntary nature of the elements is depicted with the following markings:

V/M	Description
V	The element is always voluntary. Data groups or data items marked as voluntary are included in the processing feedback, if they contain data.
M	The element is always included if its "parent element" is included.

In some elements, messages use a limited range of values, i.e. codes. The possible values of these codes are described in the "Codes" document. This document refers to the values presented in the codesets using the term "codes".



2 PROCESSING FEEDBACK (STATUSRESPONSEFROMIR)

The general structure of processing feedback delivered from the Incomes Register is as follows:

Data designation	Type	V/M
Details of the received record (DeliveryData)	smt:DeliveryData	V/M
Processing feedback data (StatusResponse)	smt:StatusResponse	M
Approved items (ValidItems)	smt:ValidItems	V
Approved item (Item)	smt:Item	M
Rejected items (InvalidItems)	smt:InvalidItems	V
Rejected item (Item)	smt:Item	M
Item errors (ItemErrors)	smt:ItemErrors	M
Error information (ErrorInfo)	smt:ErrorInfo	M
Message-level errors (MessageErrors)	smt:MessageErrors	V
Error information (ErrorInfo)	smt:ErrorInfo	M
Record-level errors (DeliveryErrors)	smt:DeliveryErrors	V
Error information (ErrorInfo)	smt:ErrorInfo	M
Signature (Signature)	xsig:SignatureType	M

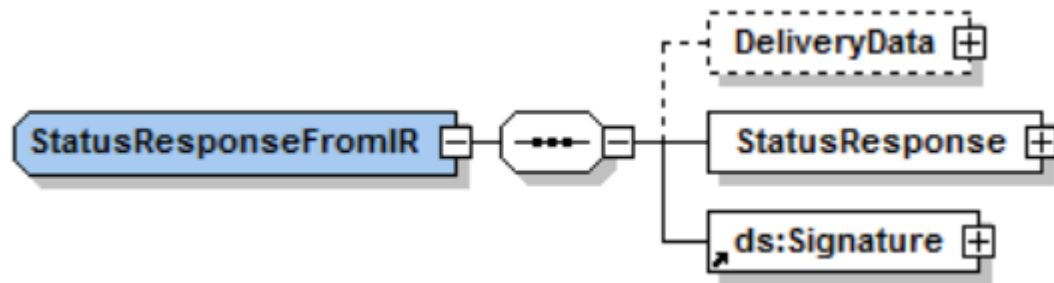

**Data group details:**

Data designation	Type	Allowed values	V/ M	Processing rule
Details of the received record (DeliveryData)	smt:DeliveryData		V/M	The general details of the received record are returned in this data group, with content that is identical to that of the received record.
Processing feedback data (StatusResponse)	smt:StatusResponse		M	The data group contains the data from the record processing feedback generated by the Incomes Register.
Signature (Signature)	xsig:SignatureType		M	The electronic signature of the record is delivered in this data group.



2.1 Details of the received record (DeliveryData)

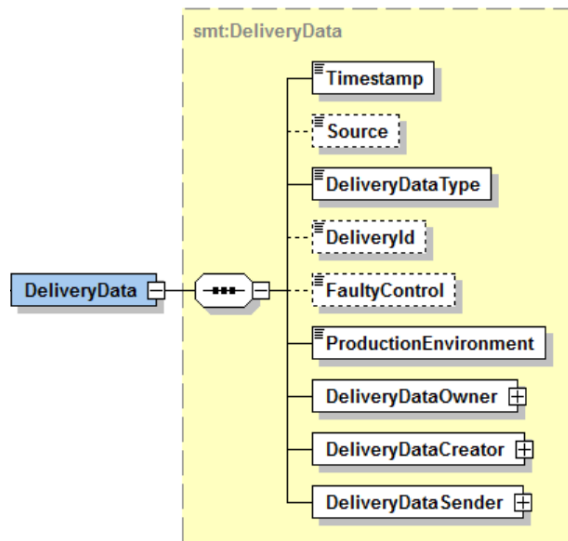

Data group details:

Data designation	Type	Allowed values	V/ M	Processing rule
Details of the received record (DeliveryData)	smt:DeliveryData		V/M	The general details of the received record are returned in this data group with content that is identical to that of the received record. The data group will be missing from the processing feedback, if the queried record is not found in the Incomes Register.
Time of record creation (Timestamp)	xs:dateTime		M	
Data source (Source)	irct:String30		V	
Record type (DeliveryDataType)	xs:int	Codes: DeliveryDataType	M	
Record owner's record reference (DeliveryId)	irct:String40		V	
Rule for processing invalid data (FaultyControl)	xs:int	Codes: FaultyControl	V	
Production environment (ProductionEnvironment)	irct:trueOrFalse	Codes: ProductionEnvironment	M	
Record owner (DeliveryDataOwner)	smt:Id		M	



Data designation	Type	Allowed values	V/ M	Processing rule
Record creator (DeliveryDataCreator)	smt:Id		M	
Record submitter (DeliveryDataSender)	smt:Id		M	



2.2 Processing feedback data (StatusResponse)

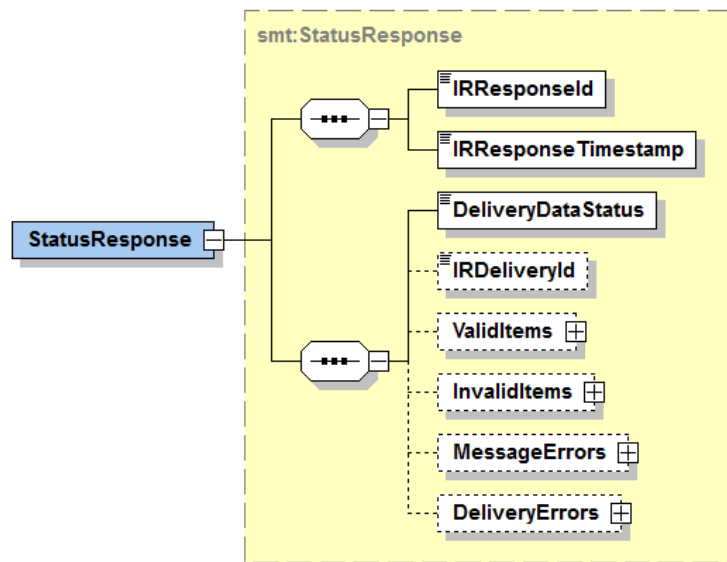

Data group details:

Data designation	Type	Allowed values	V/ M	Processing rule
Processing feedback data (StatusResponse)	smt:StatusResponse		M	The data group contains the data from the record processing feedback generated by the Incomes Register.
Incomes Register message reference (IRResponseId)	irct:Guid		M	The Incomes Register message reference uniquely identifies all messages sent from the Incomes Register.
Processing feedback timestamp (IRResponseTimestamp)	xs:dateTime		M	The date and time at which the Incomes Register generated the processing feedback.
Record status (DeliveryDataStatus)	xs:int	Codes: DeliveryDataStatus and values 0,2,3,4,5,6 derived from it	M	After the record has been processed in the Incomes Register, its status is delivered in this element.
Incomes Register record reference (IRDeliveryId)	irct:Guid		V	If the record has been saved in the Incomes Register, the reference assigned to the record by the Incomes Register is delivered in this element. The Incomes Register record reference uniquely identifies all records submitted to the Incomes Register.



Data designation	Type	Allowed values	V/ M	Processing rule
				If the record has not been saved in the Incomes Register, this data is blank.
Approved items (ValidItems)	smt:ValidItems		V	The valid items submitted in the record are returned in this data group.
Rejected items (InvalidItems)	smt:InvalidItems		V	The invalid items submitted in the record and rejected on the basis of item-specific errors are returned in this data group. If all items in the record are rejected on the basis of record-level errors, the rejected items are not returned in this data group.
Message-level errors (MessageErrors)	smt:MessageErrors		V	This data group is used to return technical and authorisation errors. If message-level errors are detected in a record submitted to the Incomes Register, the record is not processed further in the Incomes Register. In addition to message-level errors, the processing feedback cannot therefore contain any other errors (record-level errors, and rejected items and the errors related to them).
Record-level errors (DeliveryErrors)	smt:DeliveryErrors		V	This data group is used to return errors related to the contents of record-level data. Record-level errors apply to all items in the record. If there are record-level errors in the record, all items of the record are invalid and will not be saved in the Incomes Register. In such a case, the invalid items are not separately delivered in the "Rejected items" data group.



2.3 Approved items (ValidItems)

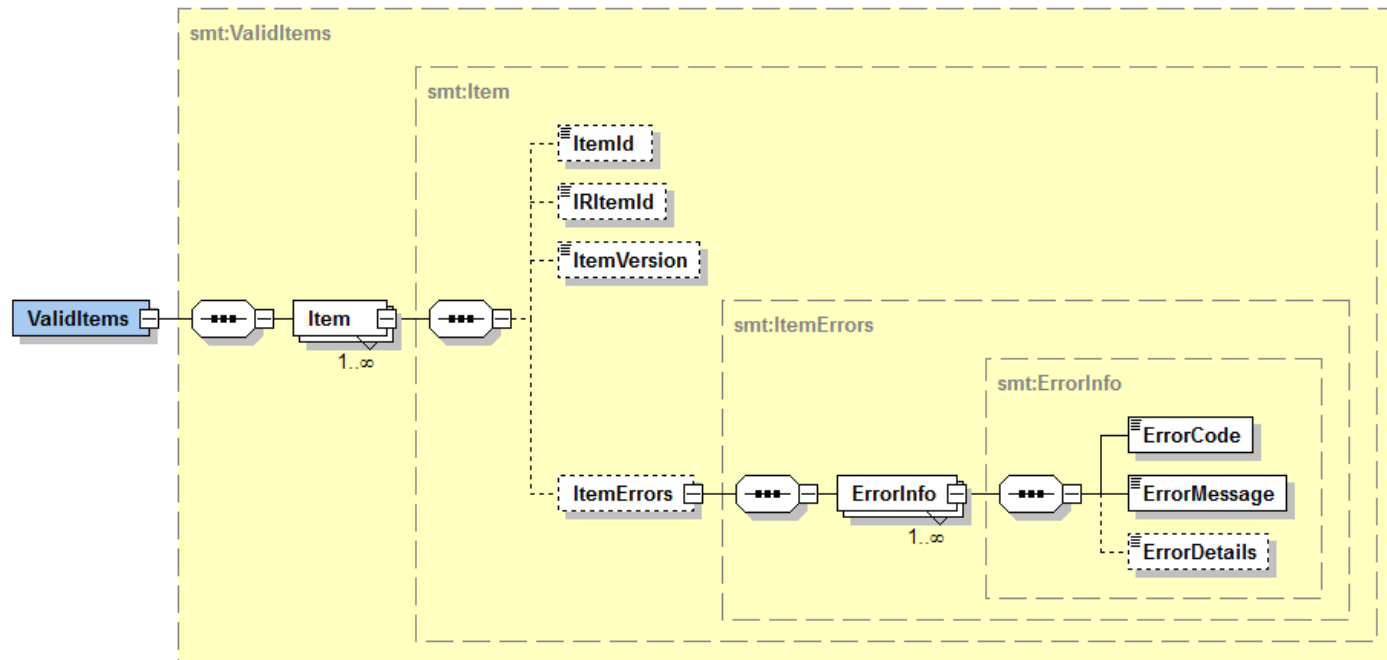

Data group details:

Data designation	Type	Allowed values	V/ M	Processing rule
Approved items (ValidItems)	smt:ValidItems		V	The approved (valid) items (reports, messages, record subscription, record) in the record are returned in this data group.
Approved item (Item)	smt:Item		M	The reports that were successfully added to the Incomes Register or substituted in the Incomes Register are returned in the section if the record type is: <ul style="list-style-type: none"> • Earnings payment reports (100) • Employer's separate reports (101) • Benefit payment reports (102)



Data designation	Type	Allowed values	V/ M	Processing rule
				<p>The data of the primary subscription that was successfully added to the Incomes Register is returned in this section if the record type is:</p> <ul style="list-style-type: none"> Record subscription (103) <p>The messages that were successfully saved in the Incomes Register are returned in this section if the record type is:</p> <ul style="list-style-type: none"> Messages (104) <p>The reports that were successfully cancelled in the Incomes Register are returned in this section if the record type is:</p> <ul style="list-style-type: none"> Cancellation of earnings payment reports (105) Cancellation of employer's separate reports (106) Cancellation of benefits payment reports (107) <p>The primary subscription data that was successfully cancelled in the Incomes Register is returned in this section if the record type is:</p> <ul style="list-style-type: none"> Cancellation of a record subscription (108) <p>The record data that was successfully cancelled in the Incomes Register is returned in this section if the record type is:</p> <ul style="list-style-type: none"> Cancellation of a record containing earnings payment reports (109) Cancellation of a record containing employer's separate reports (110) Cancellation of a record containing benefits payment reports (111) Cancellation of a record containing a record subscription (112)
Record submitter's reference (ItemId)	irct:String40		V	<p>This element always appears in the data of an approved item.</p> <p>Payer's report reference, if the record type is:</p> <ul style="list-style-type: none"> Earnings payment reports (100) Employer's separate reports (101) Benefits payment reports (102) Cancellation of earnings payment reports (105) Cancellation of employer's separate reports (106) Cancellation of benefits payment reports (107) <p>Subscriber's primary subscription reference, if the record type is:</p> <ul style="list-style-type: none"> Record subscription (103) Cancellation of a record subscription (108)



Data designation	Type	Allowed values	V/ M	Processing rule
				<p>Sender's message reference, if the record type is:</p> <ul style="list-style-type: none"> • Messages (104) <p>Payer's record reference, if the record type is:</p> <ul style="list-style-type: none"> • Cancellation of a record containing earnings payment reports (109) • Cancellation of a record containing employer's separate reports (110) • Cancellation of a record containing benefits payment reports (111) • Cancellation of a record containing a record subscription (112)
Incomes Register reference (IRItemId)	irct:Guid		V	<p>This element always appears in the data of an approved item.</p> <p>Incomes Register report reference, if the record type is:</p> <ul style="list-style-type: none"> • Earnings payment reports (100) • Employer's separate reports (101) • Benefits payment reports (102) • Cancellation of earnings payment reports (105) • Cancellation of employer's separate reports (106) • Cancellation of benefits payment reports (107) <p>The primary subscription reference assigned by the Incomes Register, if the record type is:</p> <ul style="list-style-type: none"> • Record subscription (103) • Cancellation of a record subscription (108) <p>The message reference assigned by the Incomes Register, if the record type is:</p> <ul style="list-style-type: none"> • Messages (104) <p>Incomes Register record reference, if the record type is:</p> <ul style="list-style-type: none"> • Cancellation of a record containing earnings payment reports (109) • Cancellation of a record containing employer's separate reports (110) • Cancellation of a record containing benefits payment reports (111) • Cancellation of a record containing a record subscription (112)
Report version number (ItemVersion)	xs:int		V	<p>Report version number, if the record type is:</p> <ul style="list-style-type: none"> • Earnings payment reports (100) • Employer's separate reports (101)



Data designation	Type	Allowed values	V/ M	Processing rule
				<ul style="list-style-type: none"> • Benefits payment reports (102) <p>The Incomes Register assigns version number 1 to a new report. The version number of a substitute report is the number of the substituted version + 1.</p> <p>The version number of the report to be cancelled + 1 (the version number of a report generated by the Incomes Register that has the "Cancelled" status) if the record type is:</p> <ul style="list-style-type: none"> • Cancellation of earnings payment reports (105) • Cancellation of employer's separate reports (106) • Cancellation of benefits payment reports (107)
Errors (ItemErrors)	smt:ItemErrors			The data group is not returned in the data of an approved item. The group is included in the picture for technical reasons only.



2.4 Rejected items (InvalidItems)

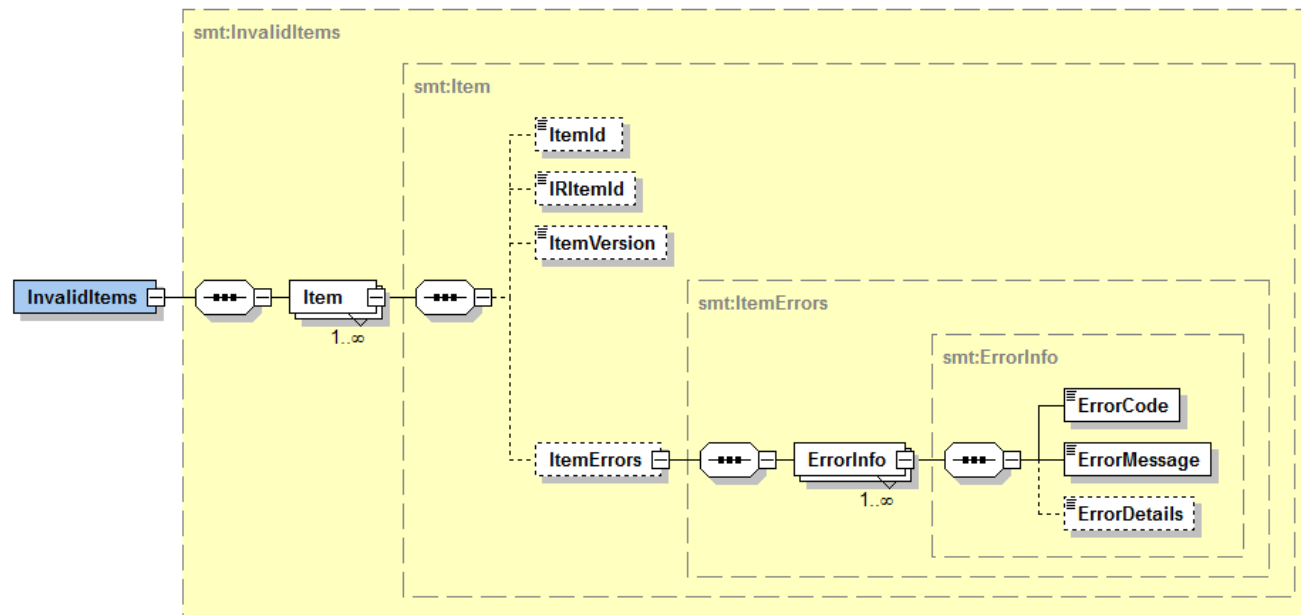

Data group details:

Data designation	Type	Allowed values	V/ M	Processing rule
Rejected items (InvalidItems)	smt:InvalidItems		V	The invalid items (reports, messages, record subscription, record) submitted in the record and rejected on the basis of item-specific errors are returned in this data group. If all items in the record are rejected on the basis of record-level errors, the rejected items are not returned in this data group.
Rejected item (Item)	smt:Item		M	The reports that could not be added to or substituted in the Incomes Register are returned in the section if the record type is: <ul style="list-style-type: none"> • Earnings payment reports (100) • Employer's separate reports (101) • Benefits payment reports (102)



Data designation	Type	Allowed values	V/ M	Processing rule
				<p>The details of the primary subscription are returned in this section if adding the subscription to the Incomes Register failed and the record type is:</p> <ul style="list-style-type: none"> Record subscription (103) <p>The messages that could not be saved in the Incomes Register are returned in the section if the record type is:</p> <ul style="list-style-type: none"> Messages (104) <p>The reports that could not be cancelled in the Incomes Register are returned in this section if the record type is:</p> <ul style="list-style-type: none"> Cancellation of earnings payment reports (105) Cancellation of employer's separate reports (106) Cancellation of benefits payment reports (107) <p>The primary subscription data is returned in this section if the cancellation in the Incomes Register failed and the record type is:</p> <ul style="list-style-type: none"> Cancellation of a record subscription (108) <p>The record data is returned in this section if the cancellation of the record in the Incomes Register failed and the record type is:</p> <ul style="list-style-type: none"> Cancellation of a record containing earnings payment reports (109) Cancellation of a record containing employer's separate reports (110) Cancellation of a record containing benefits payment reports (111) Cancellation of a record containing a record subscription (112)
Record submitter's reference (ItemId)	irct:String40		V	<p>Payer's report reference (submitted in the processed record), if the record type is:</p> <ul style="list-style-type: none"> Earnings payment reports (100) Employer's separate reports (101) Benefits payment reports (102) Cancellation of earnings payment reports (105) Cancellation of employer's separate reports (106) Cancellation of benefits payment reports (107) <p>Subscriber's primary subscription reference (submitted in the processed record), if the record type is:</p> <ul style="list-style-type: none"> Record subscription (103)

Data designation	Type	Allowed values	V/ M	Processing rule
				<ul style="list-style-type: none"> • Cancellation of a record subscription (108) <p>Sender's message reference (submitted in the processed record), if the record type is:</p> <ul style="list-style-type: none"> • Messages (104) <p>Payer's record reference (submitted in the processed record), if the record type is:</p> <ul style="list-style-type: none"> • Cancellation of a record containing earnings payment reports (109) • Cancellation of a record containing employer's separate reports (110) • Cancellation of a record containing benefits payment reports (111) • Cancellation of a record containing a record subscription (112)
Incomes Register reference (IRItemId)	irct:Guid		V	<p>Incomes Register report reference (submitted in the processed record), if the record type is:</p> <ul style="list-style-type: none"> • Earnings payment reports (100) • Employer's separate reports (101) • Benefits payment reports (102) • Cancellation of earnings payment reports (105) • Cancellation of employer's separate reports (106) • Cancellation of benefits payment reports (107) <p>Data will not be included in the feedback, if the record type is:</p> <ul style="list-style-type: none"> • Record subscription (103) • Messages (104) <p>Incomes Register primary subscription reference (submitted in the processed record), if the record type is:</p> <ul style="list-style-type: none"> • Cancellation of a record subscription (108) <p>Incomes Register record reference (submitted in the processed record), if the record type is:</p> <ul style="list-style-type: none"> • Cancellation of a record containing earnings payment reports (109) • Cancellation of a record containing employer's separate reports (110) • Cancellation of a record containing benefits payment reports (111) • Cancellation of a record containing a record subscription (112)

Data designation	Type	Allowed values	V/ M	Processing rule
Report version number (ItemVersion)	xs:int		V	Report version number (submitted in the processed record), if the record type is: <ul style="list-style-type: none"> • Earnings payment reports (100) • Employer's separate reports (101) • Benefits payment reports (102) • Cancellation of earnings payment reports (105) • Cancellation of employer's separate reports (106) • Cancellation of benefits payment reports (107)
Item errors (ItemErrors)	smt:ItemErrors		M	An itemised list of the item's errors.
Error information (ErrorInfo)	smt:ErrorInfo		M	There may be several errors.
Error code (ErrorCode)	irct:String20		M	The error code is returned in this element.
Error code description (ErrorMessage)	irct:String500		M	A description of the error code is returned in this element.
Error details (ErrorDetails)	irct:String500		V	Identifying information on the error is returned in this element.



2.5 Message-level errors (MessageErrors)

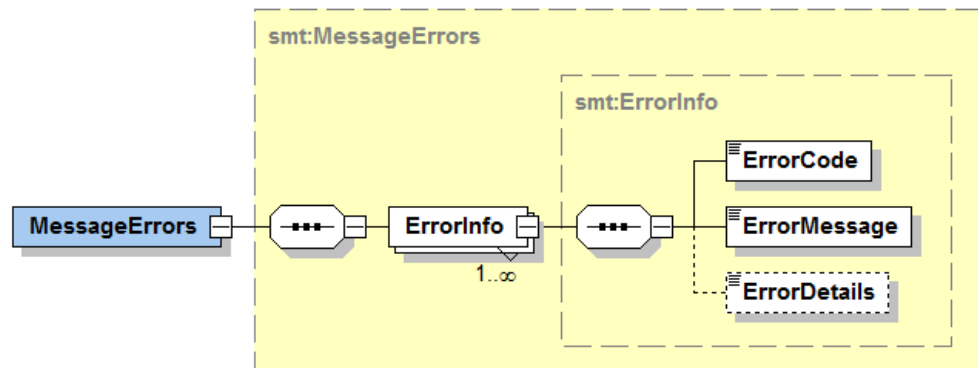

Data group details:

Data designation	Type	Allowed values	V/ M	Processing rule
Message-level errors (MessageErrors)	smt:MessageErrors		V	This data group is used to return, for example, technical and authorisation errors.
Error information (ErrorInfo)	smt:ErrorInfo		M	There may be several errors.
Error code (ErrorCode)	irct:String20		M	The error code is returned in this element.
Error code description (ErrorMessage)	irct:String500		M	A description of the error code is returned in this element.
Error details (ErrorDetails)	irct:String500		V	Allocation and identifying information for the error is returned in this element.

2.6 Record-level errors (DeliveryErrors)

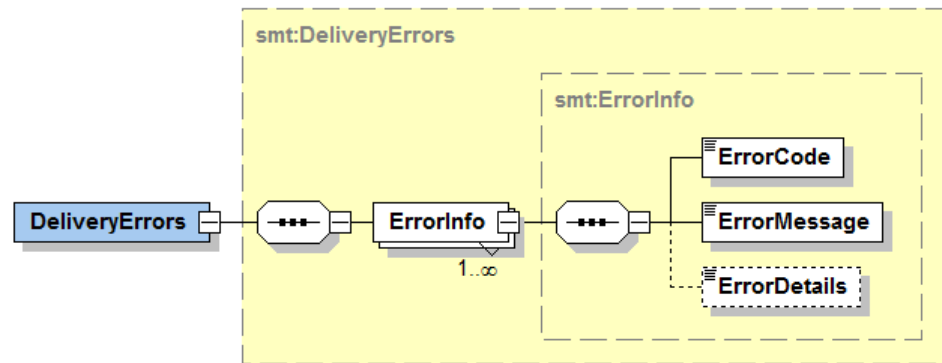

Data group details:

Data designation	Type	Allowed values	V/ M	Processing rule
Record-level errors (DeliveryErrors)	smt:DeliveryErrors		V	This data group is used to return errors related to the contents of record-level data. Record-level errors apply to all items in the record. If there are record-level errors in the record, all items of the record are invalid and will not be saved in the Incomes Register. In such a case, the invalid items are not separately delivered in the "Rejected items" data group.
Error information (ErrorInfo)	smt:ErrorInfo		M	There may be several errors.
Error code (ErrorCode)	irct:String20		M	The error code is returned in this element.
Error code description (ErrorMessage)	irct:String500		M	A description of the error code is returned in this element.
Error details (ErrorDetails)	irct:String500		V	Allocation and identifying information for the error is returned in this element.

