

# **Application for refund of tax withheld at source on dividends, interest and royalties**

Technical guidance

## Table of contents

<b>1</b>	<b>TECHNICAL GUIDANCE FOR REFUND APPLICATIONS IN THE XML FORMAT FOR TAX AT SOURCE ON DIVIDEND, INTEREST AND ROYALTY INCOME</b>	<b>4</b>
1.1	Instructions for reading	4
<b>2</b>	<b>THE ILMOITIN.FI WEBSITE</b>	<b>5</b>
2.1	Technical requirements related to the file	5
<b>3</b>	<b>DEADLINE FOR THE APPLICATIONS</b>	<b>6</b>
<b>4</b>	<b>SENDING ATTACHMENT FILES WITH AN APPLICATION</b>	<b>6</b>
<b>5</b>	<b>STRUCTURE OF THE XML SCHEMA</b>	<b>6</b>
5.1	MessageSpec	6
5.2	WhtBody	8
5.2.1	Sender	8
5.2.2	Applicant	9
5.2.2.1	Organisation	9
5.2.2.1.1	BeneficialOwnerOfTheIncome	13
5.2.2.1.2	UmbrellaFund	15
5.2.2.2	Individual	16
5.2.2.3	Summary	18
5.3	Contact	18
5.4	Address structures	19
5.4.1	AddressFree	20
5.4.2	AddressFix	20
5.5	Incomes	21
5.5.1	Income	21
5.5.1.1	Dividend	21
5.5.1.1.1	DirectOwnership	22
5.5.1.1.2	NomineeRegistered	22
5.5.1.1.3	Fund	23
5.5.1.1.4	Partnership	25
5.5.1.2	Interest	26
5.5.1.3	Royalties	27
5.6	BankInfo	28
5.6.1	IBAN	28
5.6.2	OBAN	29
5.7	DetailsOfIncome	31
5.7.1	StockExchanged	32
<b>6</b>	<b>AUTOMATED CHECK PROCESSES RUN BY ILMOITIN</b>	<b>33</b>
<b>7</b>	<b>LIST OF MESSAGES FROM ILMOITIN</b>	<b>35</b>
<b>8</b>	<b>FURTHER INFORMATION AND LINKS</b>	<b>35</b>

**VERSION HISTORY**

<b>Version</b>	<b>Date</b>	<b>Notes</b>
1.0	14.02.2020	First version published
1.01	25.02.2020	Boolean values added: true = Yes, false = No
1.02	15.04.2020	Some specifications added to content
1.03	27.05.2020	Some specifications added to content
1.04	08.06.2020	Specification to guidance for element UmbrellaFund
1.05	13.01.2022	<p>Updates to mandatory/optional requirements, for example in the BeneficialOwnerOfTheIncome structure</p> <p>Addition of element AgentsIN for reporting an identification number for the agent</p> <p>Some specifications added to content, including the elements AIN, AgentsName, TopIntermediary and OtherIntermediaries, as well as the Address structure</p>
1.06	07.02.2023	Spaces no longer allowed in elements Organisation IN and ApplicationID
1.07	13.4.2026	Spelling error corrected in 5.2.2.1.2 Umbrella Fund: IN → TIN in element under MainFund

# 1 TECHNICAL GUIDANCE FOR REFUND APPLICATIONS IN THE XML FORMAT FOR TAX AT SOURCE ON DIVIDEND, INTEREST AND ROYALTY INCOME

The format specification in this guidance must be adhered to when submitting applications to the Finnish Tax Administration for refunds of tax at source withheld on dividend, interest and royalty income.

The guidance contains a description of the technical requirements and information on how applications can be sent via the Ilmoitin.fi website.

The guidance comes into force as of 8 February 2022. Applications submitted on that date and later must meet the format requirements. Those who prepare an online application must pay attention to the Tax Administration's guidance for filling out Forms [6163](#), [6164](#) and 6167. Read more about applications for refund on the "[Financial sector](#)" – [Finanssiala ja verotus](#) pages on Tax.fi.

The refund application consists of the following main structures, listed in their required order of priority:

- MessageSpec is a structure containing the identity information of both the XML file and the party submitting the application (=the filer of the application).
- WhtBody, contains information on the application as a set of recurring structures.

The structures, elements and check processes in ilmoitin.fi are available for testing in the Ilmoitin.fi test environment (<https://testi.ilmoitin.fi/>) from 4 January 2022. They will be available and valid in the live environment ([www.ilmoitin.fi](http://www.ilmoitin.fi)) on 8 February 2022.

The guidance additionally contains a link to the XML Schema and example files that fulfil the Tax Administration requirements including "Required Yes/No" (P/V). P=Pakollinen (Mandatory), V=Valinnainen (Optional).

## 1.1 Instructions for reading

This document is intended as a guidance for those who set up the files in the XML format to request refunds for tax withheld at source on dividend, interest and royalty income.

The following characters may be shown in the bottom right of the element:

– 0...∞ means that the element may occur zero to "n" times

– and 1...∞ means that the element may occur one to "n" times.

If a solid frame surrounds an element, it means that the element is "Required", so it must be included in all submitted applications. Correspondingly, if a dotted line surrounds an element, it is an optional element. However, some of the data elements that the Schema denotes as optional are required; the check process of [www.ilmoitin.fi](http://www.ilmoitin.fi) verifies that they are included and that they have the appropriate contents. It is also recommended that optional elements are always given when applicable to the case in question. Necessary information not provided will be requested afterwards with an information request.

## 2 THE ILMOITIN.FI WEBSITE

XML-format refund applications for taxes withheld at source on dividend, interest and royalty income can be submitted electronically only through [www.ilmoitin.fi](http://www.ilmoitin.fi) (on the condition that the application has been set up in accordance with this Schema). The site is accessible both over the Web with a usual browser, and through a Web Services interface. Both test and live environments are available. The address of the test environment is <https://testi.ilmoitin.fi/>. The address of the live environment is [www.ilmoitin.fi](http://www.ilmoitin.fi). To ask for the addresses of WebServices interfaces, send e-mail to [tamo.tk@vero.fi](mailto:tamo.tk@vero.fi).

Login or other e-authentication is required before any submittals. E-authentication is done using Suomi.fi identification. You do not need to apply for a separate Suomi.fi ID for each applicant separately, but it is enough that for example the agent submitting the application identifies into the system. If you already have a Suomi.fi ID, you need [a separate role](#) specifically for submitting XML bulk submissions of applications for tax-at-source refunds and tax-at-source cards. More information on the Suomi.fi identification methods and how to acquire one can be found at <https://www.suomi.fi/instructions-and-support/information-on-eidentification>.

### 2.1 Technical requirements related to the file

The size of the XML file cannot exceed 500 MB. If the file exceeds the 500 MB limit, the information must be split into several files that are 500 MB or less each. When the information is submitted with several files, each file must have a separate MessageRefID. In such cases it is recommended that the MessageRefIDs follow sequential numbering.

The required method of encoding is UTF-8. In the interests of compatibility, we require the ISO8859-1 character set, with UTF-8 encoding. This means that characters of the Cyrillic alphabet are not recommended. The file must not contain the Byte Order Mark (BOM) character.

The following special characters must be converted into the following formats (especially & and <):

Character	Description	Must be submitted as:
&	the ampersand	&amp; conversion is mandatory
<	“less than”	&lt; conversion is mandatory

Table 1. Special characters, converted

The following table contains more rules on the characters from the IRS.

Character	Description	Must be submitted as:
>	“greater than”	&gt; conversion is not mandatory, but conforms with best practices
'	the apostrophe	&apos; conversion is not mandatory, but conforms with best practices
”	quotation marks	&quot; conversion is not mandatory, but conforms with best practices
--	double hyphen	This character must not appear in an XML file
/*	slash asterisk	This character must not appear in an XML file
&#	ampersand hash	This character must not appear in an XML file

Table 2. Further restrictions, from the IRS, on special characters

### 3 DEADLINE FOR THE APPLICATIONS

You may apply for a refund during the three calendar years that follow the year of payment and withholding. Example: if a beneficial owner was paid dividends in 2019 and you apply for refund on the taxes withheld at source, your application must arrive at the Tax Administration on 2 January 2023 at the latest. It is required that the online application arrives in the Tax Administration no later than during the date set out as the deadline. It is deemed that an online application has arrived on time if the acknowledgement of its receipt is dated no later than on the date set out as the deadline. You can prepare one single XML submission to ask for refunds for a number of applicants.

### 4 SENDING ATTACHMENT FILES WITH AN APPLICATION

More information on how to submit attachments to bulk submissions can be found in the separate guidance Electronically supplied enclosures to tax-at-source refund applications and applications for tax-at-source cards, available on the [IT developers page](#).

### 5 STRUCTURE OF THE XML SCHEMA

This section discusses the structures that require additional guidance and instructions. Descriptions of the check processes and messages provided by the [www.ilmoitin.fi](http://www.ilmoitin.fi) are found here in section 5 and in the next section, section 6.

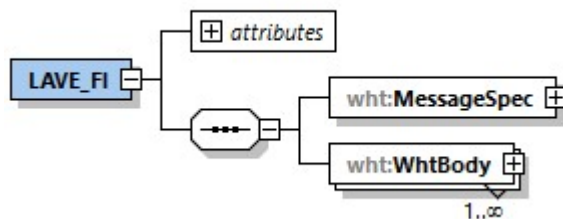

The Schema requires naming based on “wht”.

For entries with decimals, use two decimals. The separator character is the dot (.).

#### 5.1 MessageSpec

This structure is for unique, specific information on the submitted application.

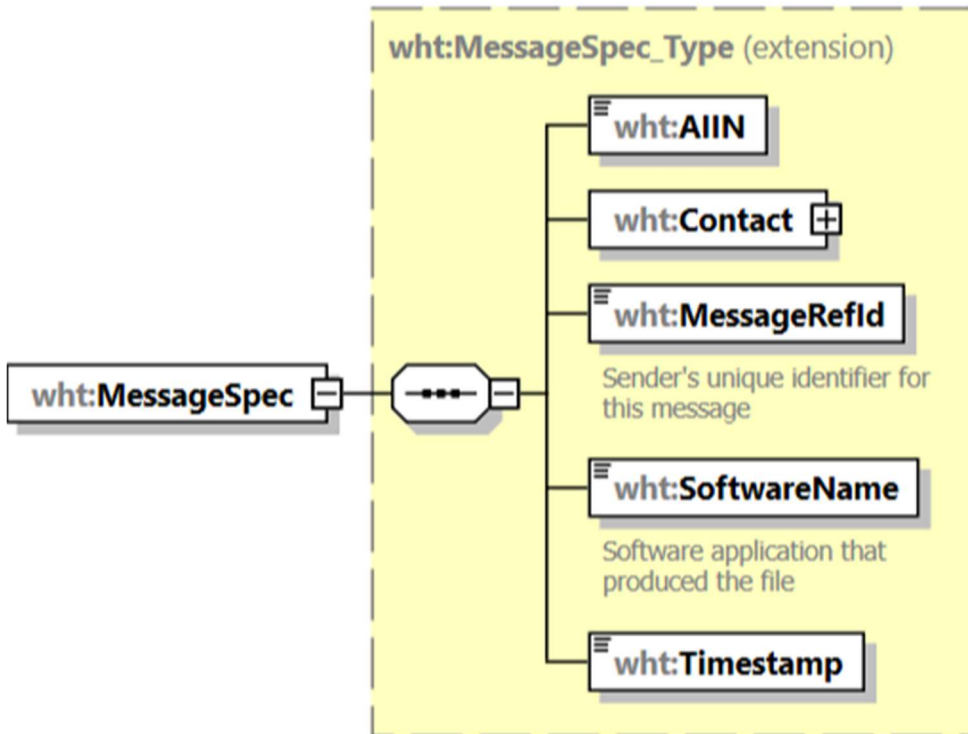

Element	Attribute	Type	P/V
AIIN		string	P

- This element is for the identification code (Business ID) of the agent/representative who actually submits the application on the portal
- The ID may be given in one of the following formats:
  - o Finnish Business ID (y-tunnus)
    - A Finnish Business ID consists of seven digits, a dash and a control mark, for example 1234567-8
  - o The TIN (taxpayer ID code format in other countries)
  - o The VAT number
  - o The trade registration number of the agent, issued by a registration authority in the agent's country
- When reporting an ID other than a Finnish Business ID, the ID cannot include dashes

Element	Attribute	Type	P/V
Contact			P

- This element is for the personal information of the technician who handled the submittal
- To look up the required structure, see [5.3 Contact](#)

Element	Attribute	Type	P/V
MessageRefID		string	P

- The unique identifier generated by the agent's software program
- It is the responsibility of the agent (i.e. their software program) to make sure the same MessageRefID is only used once
  - o However, in the case of a replacement application, the original MessageRefID must be used
- The software of the agent submitting the application must generate its unique identifier based on the following: application type (WHT), a code number, the year of submittal, a sequential running digit. Examples of unique identifiers:
  - o WHT-6606611-7-2020-1
  - o WHT-1267865345-2020-001
- The check process on [www.ilmoitin.fi](http://www.ilmoitin.fi) verifies the format: application type – the code – the year – a sequential number
- An error message appears if an identifier is entered that has been used previously

Element	Attribute	Type	P/V
SoftwareName		string	P

- This element is for the name of the software that produced the file

Element	Attribute	Type	P/V
Timestamp		dateTime	P

- This element is for the date and time, e.g. 2020-05-02T09:30:45Z to indicate when the application was submitted

## 5.2 WhtBody

This structure contains information on the application as a set of recurring structures.

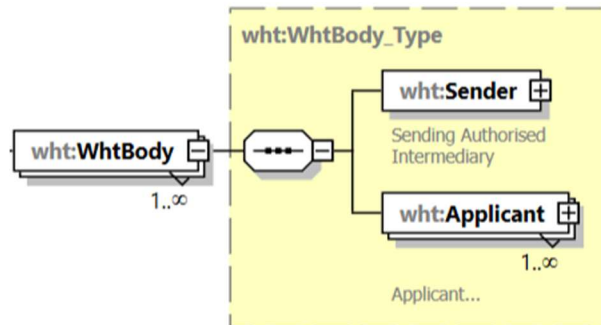

### 5.2.1 Sender

This structure is for the information on the agent or representative. Information requests and decision letters will be sent to the agent specified in this structure.

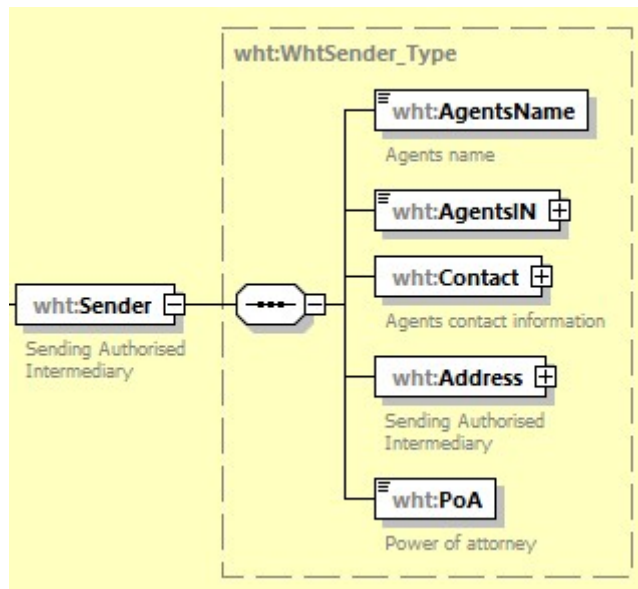

Element	Attribute	Type	P/V
AgentsName		string	P

- This element is for the name of the agent or representative, etc. – this may be an Authorized Representative, a Custodian, an Intermediary, a Consulting Firm
- For the purpose of written correspondence, write a contact name or department at the end of the name
  - For example: Agent Plc / John Smith

Element	Attribute	Type	P/V
AgentsIN		string	P

- This element is for the identification code of the agent/representative
- There may be several ID formats:
  - o The Finnish Business ID (=y-tunnus)
    - If the acting agent is an Authorised Intermediary (AI), provide the Finnish Business ID given to the AI
    - A Finnish Business ID consists of seven digits, a dash and a control mark, for example 1234567-8
  - o The TIN (taxpayer ID code format in other countries)
  - o The VAT number
  - o The trade registration number of the agent, issued by a registration authority in the agent's country

Element	Attribute	Type	P/V
Contact			P

- This element is for the agent's or representative's name, address, department, etc.
- To look up the required structure, see [5.3 Contact](#)

Element	Attribute	Type	P/V
Address			P

- This element is for the agent's or representative's address
- For more information, see [5.4 Address structures](#)

Element	Attribute	Type	P/V
PoA		boolean	P

- This element is for indicating whether a power of attorney is enclosed or not
- Values:
  - o true = Yes
  - o false = No

## 5.2.2 Applicant

This structure is for the applicant's information, given in a series of recurring structures

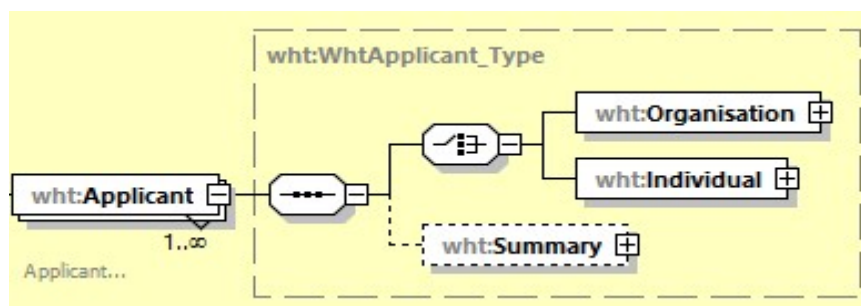

### 5.2.2.1 Organisation

This structure is for information on the organisation requesting refund

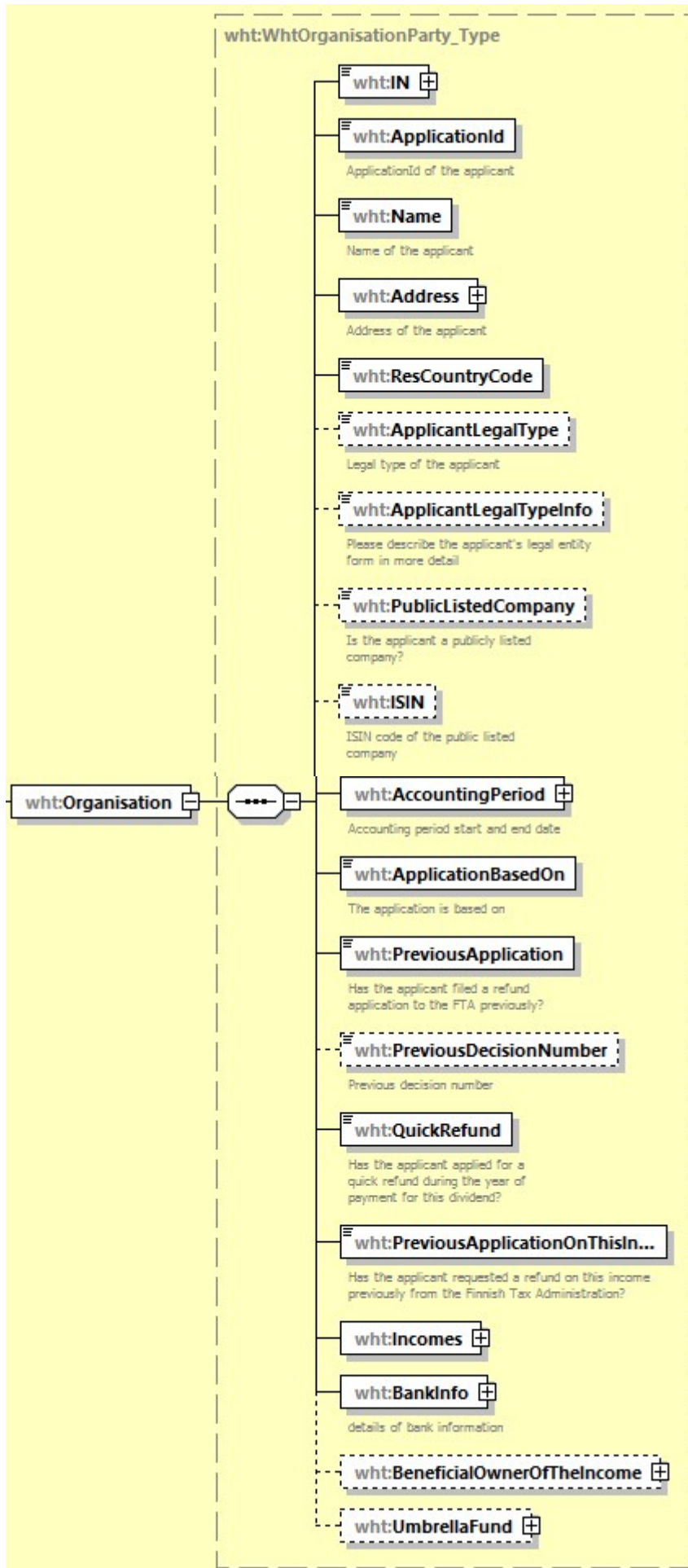

Element	Attribute	Type	P/V
IN			P
	IssuedBy		
	inType		

- This element is for the IN or TIN of the organisation
- Attribute
  - o issuedBy
    - The country of issue of the TIN or IN
    - The 2-character Country Code
  - o inType
    - TIN (Tax identification number), e.g. a Finnish Business ID or tax identification number issued by local tax officials
    - GIIN, identifier issued by the IRS for FATCA reporting
    - IN (Identification number), if a TIN or GIIN is unavailable
- Ilmoitin will check that the IN contains no spaces

Element	Attribute	Type	P/V
ApplicationId		string	P

- This element is for a reference number, generated for the organisation to help identify the submitted application
- The ID is mainly used for purposes of matching any enclosures and attachment files with the applicant's application form
  - o Similarly the ID can be used in communication with the Tax Administration
- The ApplicationID must be given in the following format: application type (WHT)\_IN/TIN\_year application is sent\_reference of your choice, e.g. WHT\_6606611-7\_2020\_00001
  - o Based on this information it is possible to match application enclosures to the correct applicant
- Ilmoitin will check whether the ApplicationID is unique
- Ilmoitin will check that the ApplicationID contains no spaces

Element	Attribute	Type	P/V
Name		string	P

- This element is for the official name of the organisation

Element	Attribute	Type	P/V
Address			P

- This element is for the address of the organisation
- For more information, see [5.4 Address structures](#)

Element	Attribute	Type	P/V
ResCountryCode		iso:CountryCode_Type	P

- This element is for the country of tax residence

Element	Attribute	Type	P/V
ApplicantLegalType			V

- This element is for the legal form of the organisation
- Values:
  - o WHT401=Corporate entity
  - o WHT402=State, municipality or other public entity
  - o WHT403=Charity or association
  - o WHT404=Pension institution or fund
  - o WHT405=UCITS fund
  - o WHT406=Non-UCITS fund
  - o WHT407=Trust
  - o WHT408=Estate
  - o WHT409=Other

- WHT410=Consortium
- You can only choose one option. If none of the options directly applies to the applicant, choose WHT 490=Other and give a more detailed description of the applicant's legal form in the element ApplicantLegalTypeInfo

Element	Attribute	Type	P/V
ApplicantLegalTypeInfo		string	V

- This element is for more detailed information on the legal form

Element	Attribute	Type	P/V
PublicListedCompany		boolean	V

- This element is for indicating whether the organisation is publically listed or non-listed
- Values:
  - true = Yes
  - false = No

Element	Attribute	Type	P/V
ISIN		string	V/P

- This element is for the ISIN of the organisation
- This is a required data element if "Yes" has been entered in PublicListedCompany

Element	Attribute	Type	P/V
AccountingPeriod			P

Element	Attribute	Type	P/V
StartDate		Date	P

- This element is for the start date of the organisation's fiscal year in the form yyyy-mm-dd

Element	Attribute	Type	P/V
EndDate		Date	P

- This element is for the end date of the organisation's fiscal year in the form yyyy-mm-dd

Element	Attribute	Type	P/V
ApplicationBasedOn		string	P

- This element is for indicating the reason for requesting refund of tax at source
- Permissible values:
  - WHT101 = Tax convention
  - WHT102 = EU Law
  - WHT103 = Other reason

Element	Attribute	Type	P/V
PreviousApplication		Boolean	P

- This element is for indicating whether an application for refund of tax at source has been submitted previously
- Values
  - true = Yes
  - false = No

Element	Attribute	Type	P/V
PreviousDecisionNumber		string	V/P

- This element is for a possible Decision number the applicant may already have, in the form that it is stated in the decision letter
- This is a required data element if "Yes" has been entered in PreviousDecisionNumber
  - If the decision number is unknown, report "unknown" in the element

Element	Attribute	Type	P/V
QuickRefund		Boolean	P

- This element is for indicating whether the applicant has asked the payer to give a refund during the year of payment for at least one of the specified incomes
- Values
  - o true = Yes
  - o false = No

Element	Attribute	Type	P/V
PreviousApplicationOnThisIncome		Boolean	P

- This element is for indicating whether the income concerned by the application has been subject to a previous request for refund from the Finnish Tax Administration concerning at least one of the specified incomes
- Values
  - o true = Yes
  - o false = No

Element	Attribute	Type	P/V
Incomes			P

- This element is for information on the applicant's income
- For more information, see [5.5 Incomes](#)

Element	Attribute	Type	P/V
BankInfo			P

- This element is for the applicant's bank information
- For more information, see [5.6 BankInfo](#)

Element	Attribute	Type	P/V
BeneficialOwnerOfTheIncome			V

- For more information, see [5.2.2.1.1 BeneficialOwnerOfTheIncome](#)

Element	Attribute	Tyyppi	P/V
UmbrellaFund			V

- For more information, see [5.2.2.1.2 UmbrellaFund](#)

#### 5.2.2.1.1 BeneficialOwnerOfTheIncome

This structure is for information on in what way the applicant – an organisation – has the right to the dividends in question.

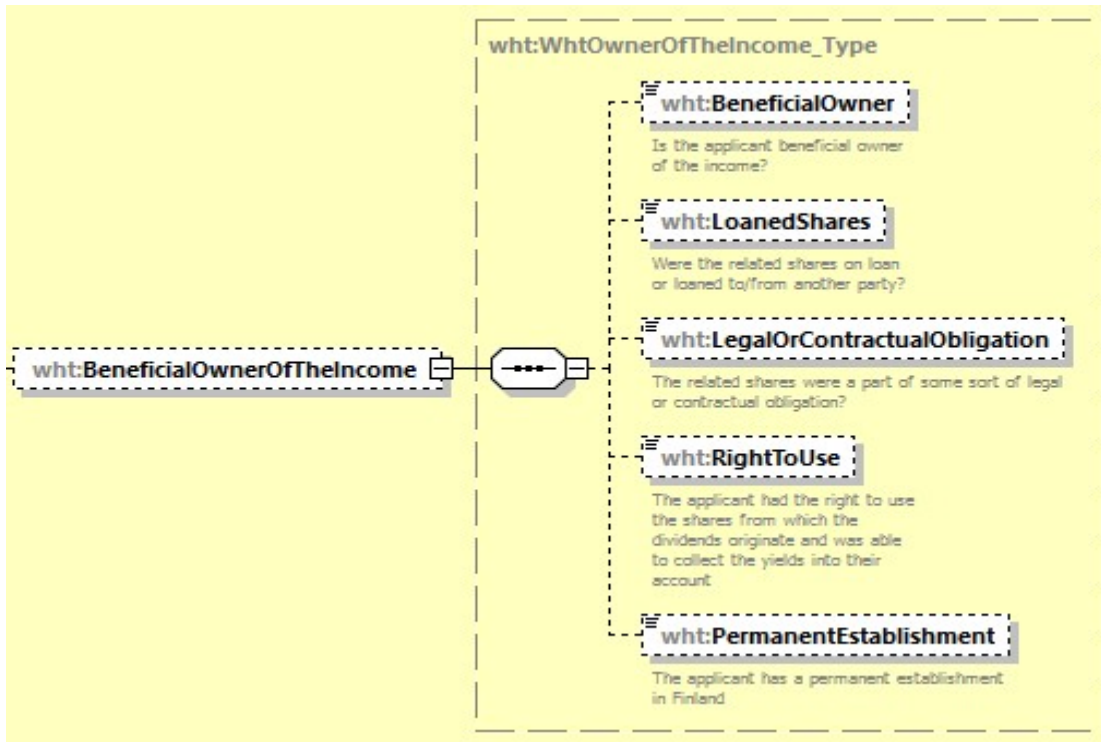

Element	Attribute	Type	P/V
BeneficialOwner		boolean	V

- This element is for stating whether the applicant is the beneficial owner (Yes/No) of the income
- Values:
  - o true = Yes
  - o false = No

Element	Attribute	Type	P/V
LoanedShares		boolean	V

- This element is for stating whether the shares were part of a lending agreement (Yes/No)
- Values:
  - o true = Yes
  - o false = No

Element	Attribute	Type	P/V
LegalOrContractualObligation		boolean	V

- This element is for stating whether the shares were part of some other legal or contractual obligation (Yes/No)
- Values:
  - o true = Yes
  - o false = No

Element	Attribute	Type	P/V
RightToUse		boolean	V

- This element is for giving a statement on whether the applicant has rights over the shares on which dividends were paid to the applicant's account (Yes/No)
- Values:
  - o true = Yes
  - o false = No

Element	Attribute	Type	P/V
PermanentEstablishment		boolean	V

- This element is for stating whether the applicant has a permanent establishment in Finland (Yes/No)
- Values:
  - o true = Yes

- false = No

### 5.2.2.1.2 UmbrellaFund

This structure is for the main fund or the sub-fund of an umbrella fund.

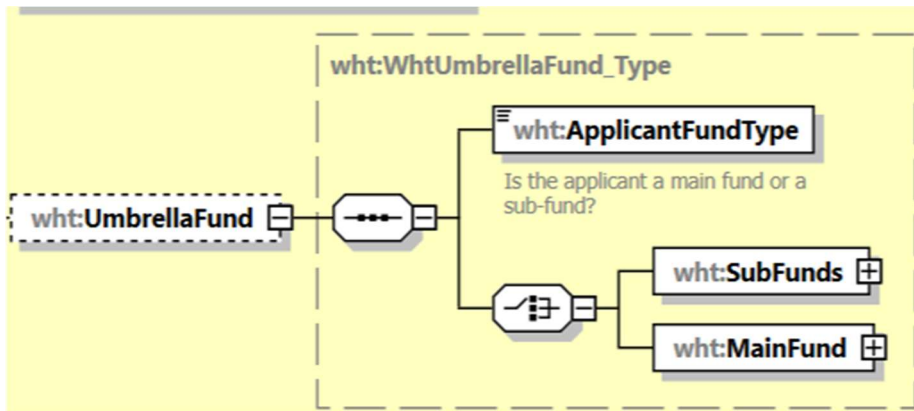

Element	Attribute	Type	P/V
ApplicantFundType			P

- This element is for stating whether the applicant is a main fund or a sub-fund
- Permissible values:
  - WHT901 = Main fund
  - WHT902 = Sub-fund

Element	Attribute	Type	P/V
SubFunds		string	V

- This element is for the name of the sub-fund, to be used in situations where the ApplicantFundType is the main fund

Element	Attribute	Tyyppi	P/V
SubFundName			P

- This element is for giving the names of the sub-funds in reoccurring structures, when the ApplicantFundType is main fund.

Element	Attribute	Type	P/V
MainFund		string	V

- This element is for the name, and TIN, of the main fund in situations where the ApplicantFundType is a sub-fund

Element	Attribute	Type	P/V
NameOfTheMainFund		string	P

- This element is for the name of the main fund
- This is a required element when the MainFund element is included

Element	Attribute	Type	P/V
TIN			P
	issuedBy		
	INType		

- This element is for the TIN/IN of the main fund
- Attribute
  - TIN (Tax identification number), e.g. a Finnish Business ID or tax identification number issued by local tax officials
  - GIIN, identifier issued by the IRS for FATCA reporting
  - IN (Identification number), if a TIN or GIIN is unavailable
- This is a required element when the MainFund element is included

### 5.2.2.2 Individual

This structure is for the personal data of the applicant, a natural person, requesting refund.

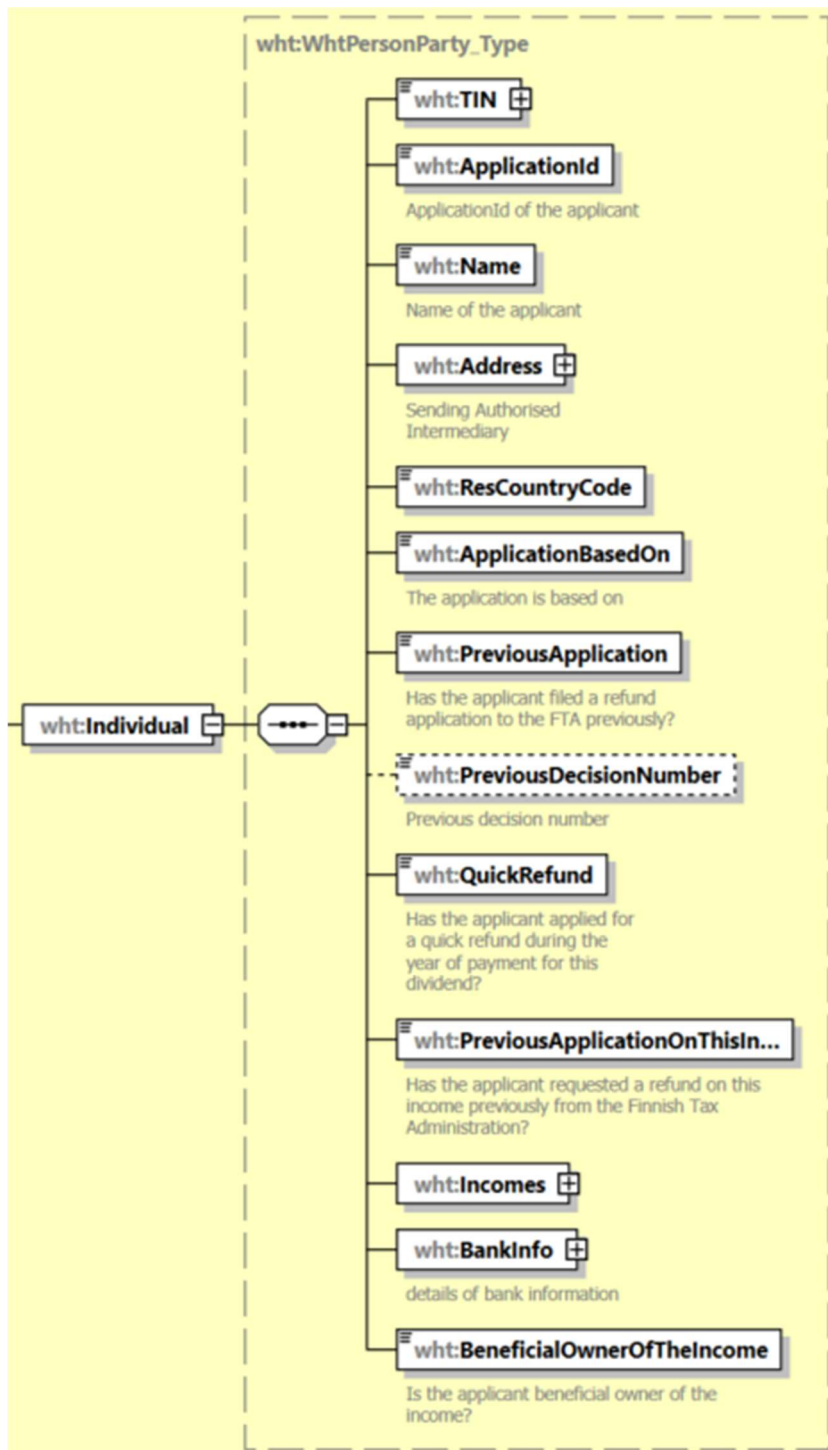

Element	Attribute	Type	P/V
TIN	issuedBy		P

- This element is for the natural person's TIN (Tax identification number)
- Attribute issuedBy
  - o The country of issue of the TIN
  - o The 2-character Country Code
- If the TIN is issued by an EU Member State, its validity will be checked
- If the applicant lives in a country, where TIN is not applicable, give some other identifier

Element	Attribute	Type	P/V
ApplicationId		string	P

- This element is for a reference number, generated for the natural person to help identify the submitted application
- The ID is mainly used for purposes of matching any enclosures and attachment files with the applicant's application form
- The ApplicationID must be given in the following format: application type (WHT)\_IN/TIN\_year application is sent\_reference of your choice, e.g. WHT\_6606611-7\_2020\_00001
- Ilmoitin will check whether the ApplicationID is unique
- Ilmoitin will check that the ApplicationID contains no spaces

Element	Attribute	Type	P/V
Name		string	P

- This element is for the natural person's name
  - o The name is given in the format: Surname, First name(s)

Element	Attribute	Type	P/V
Address			P

- This element is for the natural person's address information
- For more information, see [5.4 Address structures](#)

Element	Attribute	Type	P/V
ResCountryCode		iso:CountryCode_Type	P

- This element is for the country of tax residence of the natural person

Element	Attribute	Type	P/V
ApplicationBasedOn		string	P

- This element is for indicating the reason for requesting refund of tax at source
- Permissible values:
  - o WHT101 = Tax convention
  - o WHT102 = EU Law
  - o WHT103 = Other reason

Element	Attribute	Type	P/V
PreviousApplication		boolean	P

- This element is for indicating whether an application for refund of tax at source has been submitted previously
- Values:
  - o true = Yes
  - o false = No

Element	Attribute	Type	P/V
PreviousDecisionNumber		string	V

- This element is for any possible previous Decision number, in the form that it appears on the decision letter

Element	Attribute	Type	P/V
QuickRefund		boolean	P

- This element is for indicating whether the applicant has asked the payer to give a refund during the year of payment for at least one of the specified incomes
- Values:
  - o true = Yes
  - o false = No

Element	Attribute	Type	P/V
PreviousApplicationOnThisIncome		boolean	P

- This element is for indicating whether the income concerned by the application has been subject to a previous request for refund from the Finnish Tax Administration concerning at least one of the specified incomes
- Values:
  - o true = Yes
  - o false = No

Element	Attribute	Type	P/V
Incomes			P

- This element is for information on the applicant's income
- For more information, see [5.5 Incomes](#)

Element	Attribute	Type	P/V
BankInfo			P

- This element is for the applicant's bank information
- For more information, see [5.6 BankInfo](#)

Element	Attribute	Type	P/V
BeneficialOwnerOfTheIncome		boolean	P

- This element is for stating whether the applicant is the beneficial owner of the incomeValues:
  - o true = Yes
  - o false = No

### 5.2.2.3 Summary

This structure is for a summary of all income, paid taxes, and requested refunds for a specific applicant on one application.

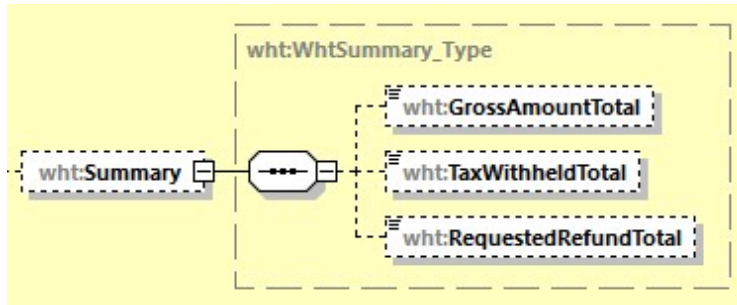

Element	Attribute	Type	P/V
GrossAmountTotal		decimal	V

- This element is for a summary of a specific applicant's all gross income

Element	Attribute	Type	P/V
TaxWithheldTotal		decimal	V

- This element is for a summary of a specific applicant's all taxes at source that were withheld

Element	Attribute	Type	P/V
RequestedRefundTotal		decimal	V

- This element is for a summary of a specific applicant's all taxes at source for which refunds have been requested

## 5.3 Contact

Give the contact information for a person who can provide additional information in this structure.

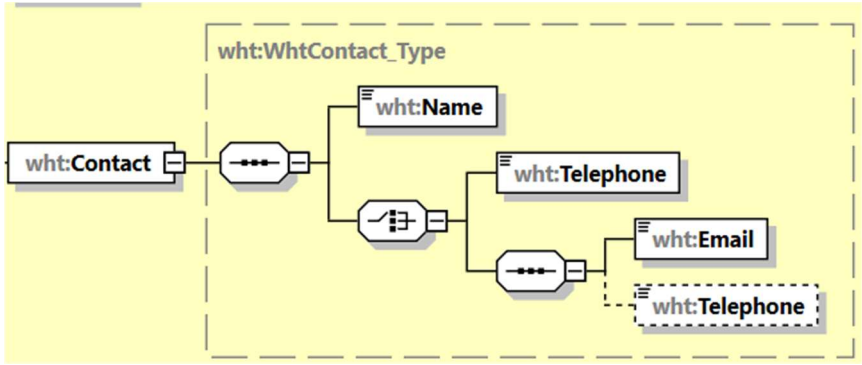

Element	Attribute	Length	Type	Required Yes/No
Name		Min 1 character	string	P
Email		Max 254 characters	string	V/P
Telephone		Min 6 characters	string	V/P

- This element is for filling in the last name and first name of the person who can give more information about the application, including a phone number (international) and an e-mail address.
- Required minimum information: you must give at least one piece of contact information; either a phone number or an e-mail
  - o The email address given can also be a group email

### 5.4 Address structures

Address information must be given with either the AddressFix or AddressFree structure. The AddressFree structure is only used when it is not possible to report address information with the AddressFix structure.

If you are using AddressFix to facilitate address reporting, this structure must include the full street address, with at least the following details

- Street address
- Post office (town or city)
- Postal code

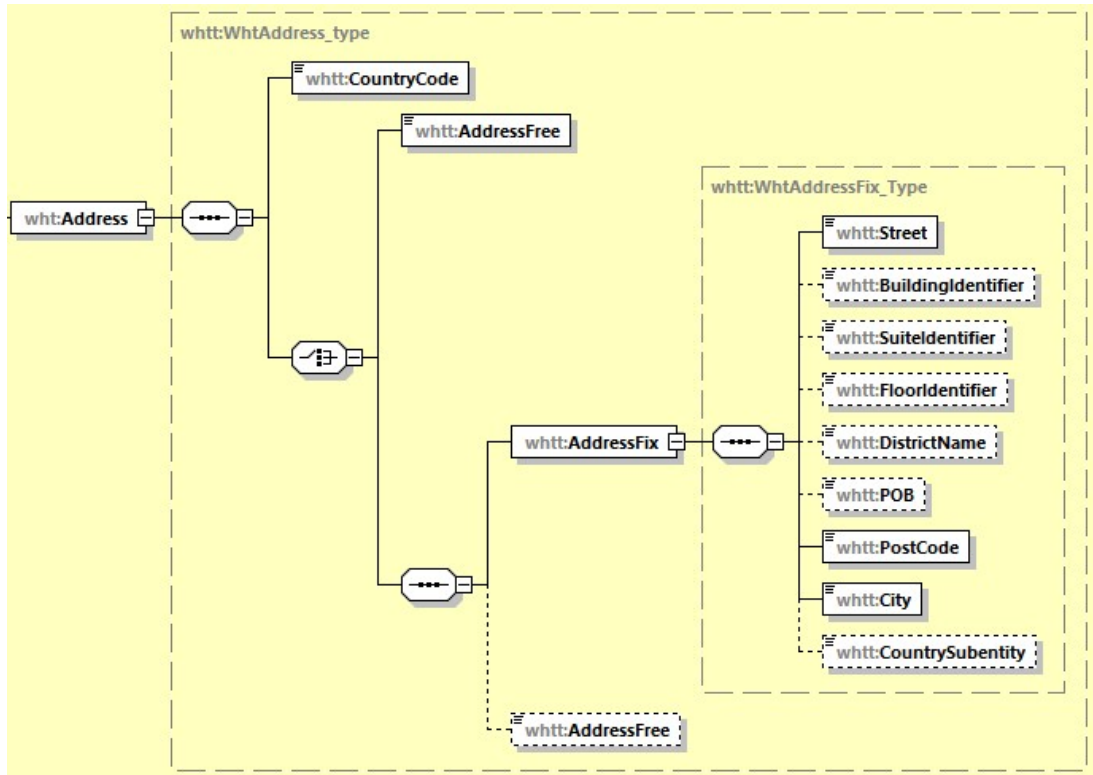

Element	Attribute	Type	P/V
CountryCode		iso:CountryCode_Type	P

- Country of location of the address
- The 2-character Country Code (ISO-3166-1 Alpha 2)

#### 5.4.1 AddressFree

This data element is in use in cases where the address cannot be entered in the AddressFix structure.

Element	Attribute	Type	P/V
AddressFree		string	V

- This element is a free-text field for address information
- Recommended address format is first the street, then the town or city (=post office) and finally the postal code
- This element is secondary while AddressFix is the primary element
- If your AddressFix structure contains all the necessary address information, you should leave out AddressFree
- However, this is a required element if no address has been given in the AddressFix structure
  - o A check process makes sure that at least 7 characters are entered.
- The address is a required data element and it must always be reported if the party submitting the application knows the address
- If the party submitting the application does not have any current address or previously valid address on file, it can be reported as "Unknown" in the AddressFree element
  - o This means that the party submitting the application has declared and affirmed that it does not know the address, and that applicable law does not require that it should know the address

#### 5.4.2 AddressFix

This structure is for address information.

Element	Attribute	Type	P/V
Street		string	P

- Street name
- Enter the word "unknown" if you do not know
- Ilmoitin makes a check to ascertain that some information is entered here

Element	Attribute	Type	P/V
BuildingIdentifier		string	V

- House no./Building no.

Element	Attribute	Type	P/V
SuiteIdentifier		string	V

- Apartment number, etc.

Element	Attribute	Type	P/V
FloorIdentifier		string	V

- The floor or storey in the building

Element	Attribute	Type	P/V
DistrictName		string	V

- Name of the neighbourhood, district, section of the town

Element	Attribute	Type	P/V
POB		string	V

- P.O. Box

Element	Attribute	Type	P/V
PostCode		string	P

- Postal code
- Ilmoitin makes a check to ascertain that some information is entered here
- Minimum length is 1
- Enter "00000" if you do not know the postal code

Element	Attribute	Type	P/V
City		string	P

- City/Municipal entity
- Enter the word "unknown" if you do not know the name of the town or city

Element	Attribute	Type	P/V
CountrySubentity		string	V

- Province or other sub-entity of the country

## 5.5 Incomes

This structure, consisting of recurring "Income" structures, is for specific information on the items of income.

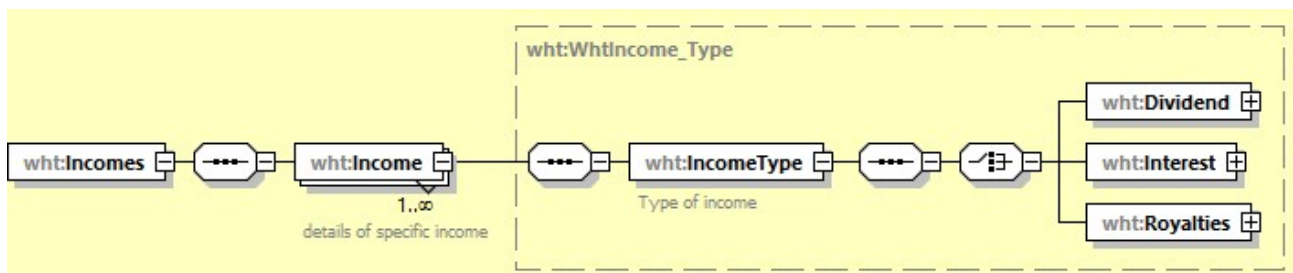

### 5.5.1 Income

Element	Attribute	Type	P/V
IncomeType			P

- This element is for indicating whether the income is dividend, interest or royalty income.

#### 5.5.1.1 Dividend

This structure is for unique information regarding the dividend income

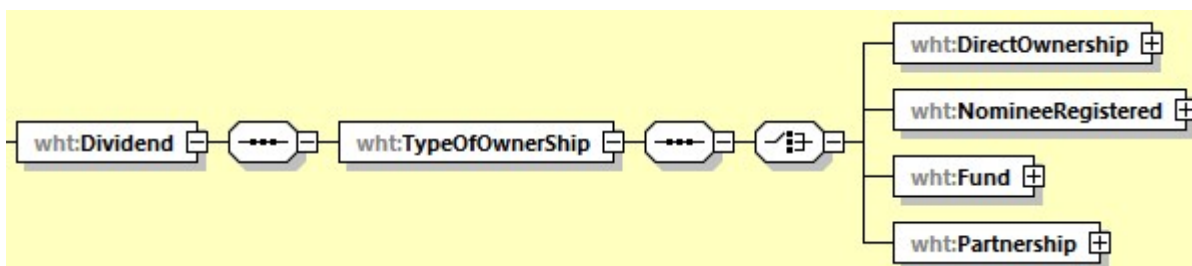

Element	Attribute	Type	P/V
TypeOfOwnership			P

- This element is for indicating ownership information, in DirectOwnership, NomineeRegistered, Fund or Partnership structures.

5.5.1.1.1 DirectOwnership

This structure is for dividends based on direct investment.

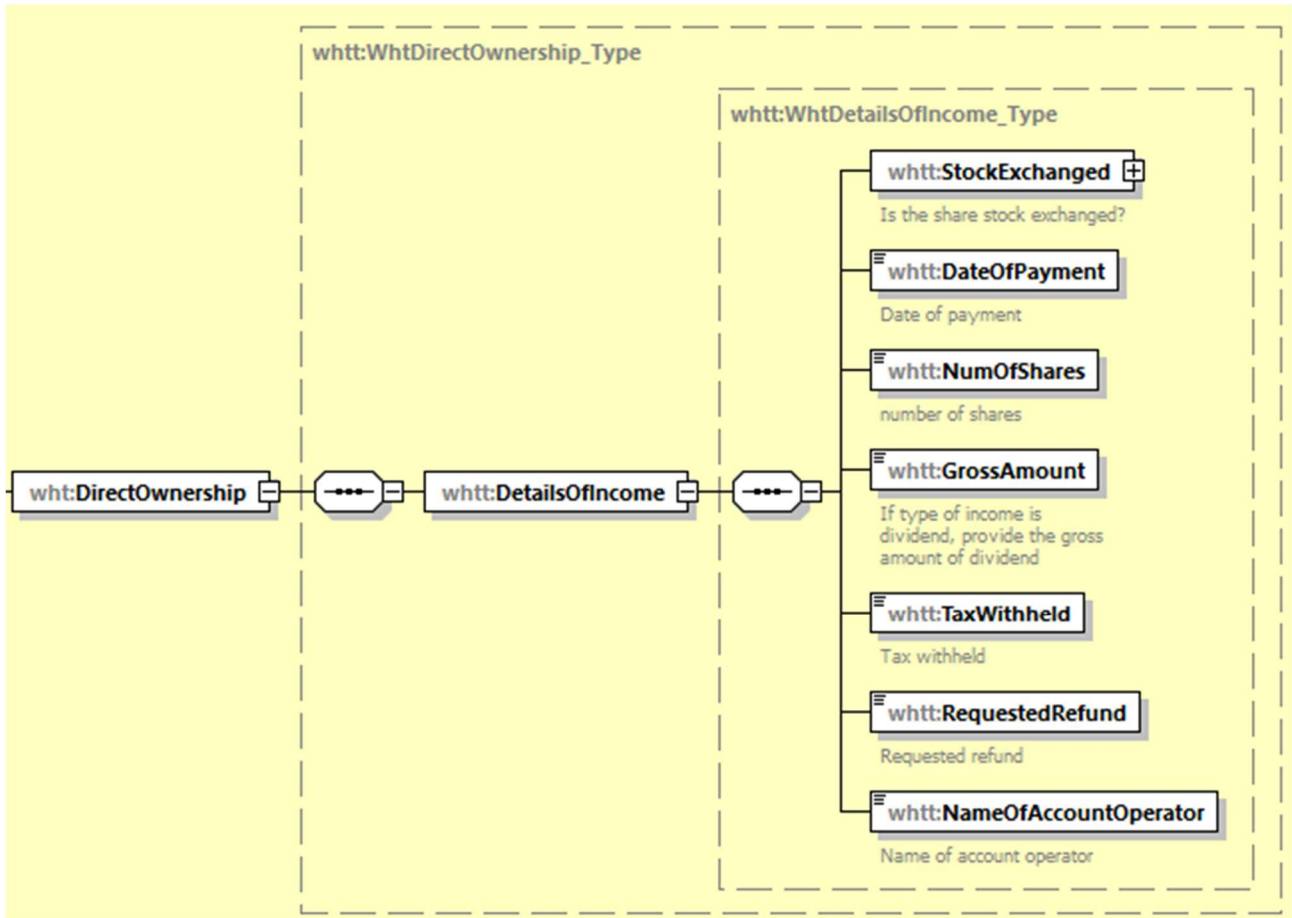

Element	Attribute	Type	P/V
StockExchanged			P

- This structure is for indicating whether the payer is a stock-exchange listed entity (Yes/No) and for the payer’s name and identity
- For more information, see [5.7.1 StockExchanged](#)

Element	Attribute	Type	P/V
DetailsOfIncome			P

- This structure is for details on payments of dividends
- For more information, see [5.7 DetailsOfIncome](#)

5.5.1.1.2 NomineeRegistered

This structure is for dividends paid on shares that are nominee-registered.

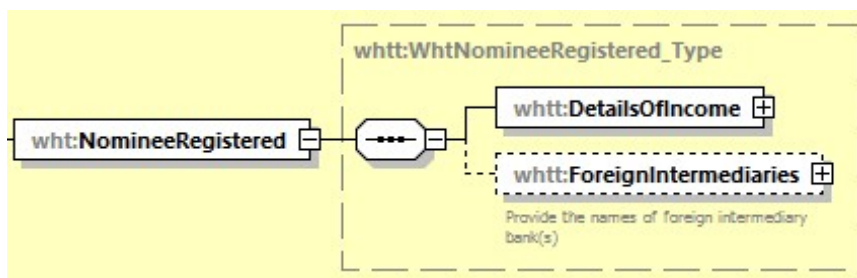

Element	Attribute	Type	P/V
DetailsOfIncome			P

- This structure is for details on payments of dividends
- For more information, see [5.7 DetailsOfIncome](#)

Element	Attribute	Type	P/V
ForeignIntermediaries			V

- This structure is for information on the financial intermediaries that transferred the income

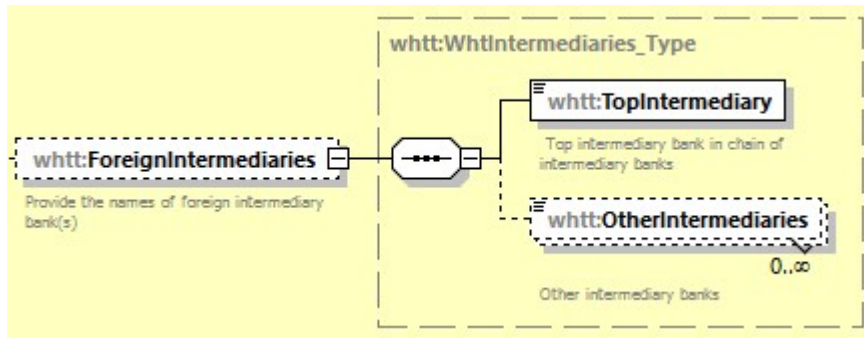

Element	Attribute	Type	P/V
TopIntermediary		string	P

- When the income was paid before 2021: This element is for the name of the first intermediary outside Finland
- When the income was paid 2021 or thereafter: This element is for the name of the intermediary closest to the income beneficiary in the reporter's knowledge

Element	Attribute	Type	P/V
OtherIntermediaries		string	V

- This element is for the names of the other intermediaries in the custody chain, filled in to recurring structures
  - All intermediaries in the reporter's knowledge are reported, regardless of whether the intermediaries are Authorised Intermediaries or Contractual Intermediaries

#### 5.5.1.1.3 Fund

This structure is for reporting any dividends paid to beneficiaries through an investment fund.

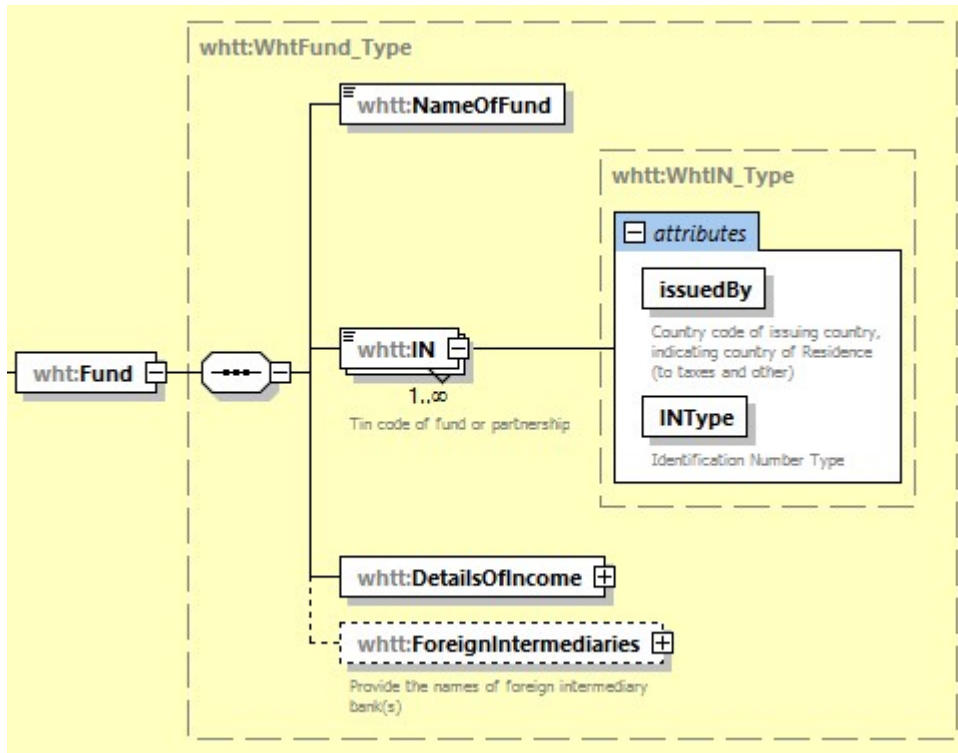

Element	Attribute	Type	P/V
NameOfFund		string	P

- This element is for the name of the fund

Element	Attribute	Type	P/V
IN			V
	IssuedBy		
	INType		

- This element is for the TIN/IN of the fund
- Attribute
  - o issuedBy
    - The country of issue of the TIN or IN
    - The 2-character Country Code
  - o inType
    - TIN (Tax identification number), e.g. a Finnish Business ID or tax identification number issued by local tax officials
    - GIIN, identifier issued by the IRS for FATCA reporting
    - IN (Identification number), if a TIN or GIIN is unavailable

Element	Attribute	Type	P/V
DetailsOfIncome			P

- This structure is for submitting information on paid-out dividends
- For more information, see [5.7 DetailsOfIncome](#)

Element	Attribute	Type	P/V
ForeignIntermediaries			V

This structure is for information on the financial intermediaries that transferred the income

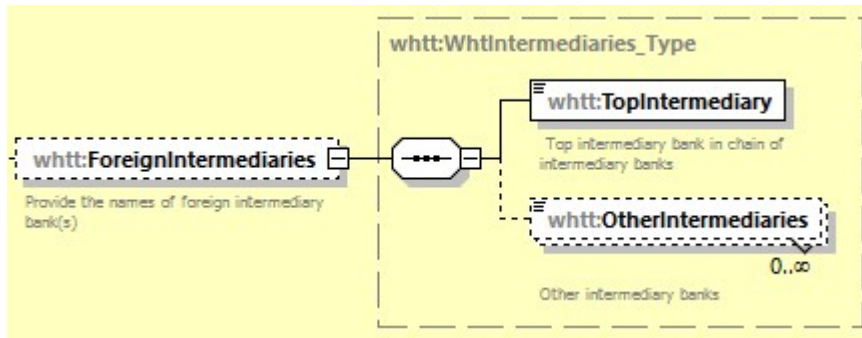

Element	Attribute	Type	P/V
TopIntermediary		string	P

- When the income was paid before 2021: This element is for the name of the first intermediary outside Finland
- When the income was paid 2021 or thereafter: This element is for the name of the intermediary closest to the income beneficiary in the reporter's knowledge

Element	Attribute	Type	P/V
OtherIntermediaries		string	V

- This element is for the names of the other intermediaries in the custody chain, filled in to recurring structures
  - All intermediaries in the reporter's knowledge are reported, regardless of whether the intermediaries are Authorised Intermediaries or Contractual Intermediaries

#### 5.5.1.1.4 Partnership

This structure is for reporting any dividends paid to beneficiaries through a partnership or consortium.

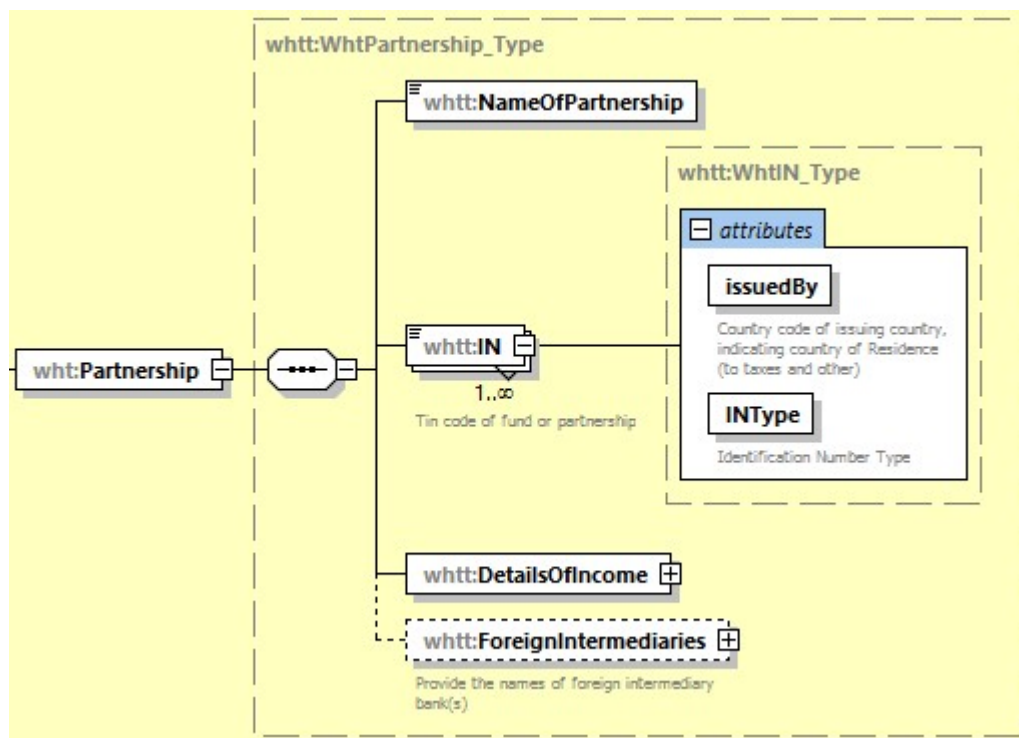

Element	Attribute	Type	P/V
NameOfPartnership		string	P

- This element is for the name of the partnership or consortium through which the payment of dividends was effected

Element	Attribute	Type	P/V
IN			P
	IssuedBy		
	INType		

- This element is for the ID code of the partnership or consortium through which the payment of dividends was effected
- Attribute
  - issuedBy
    - The country of issue of the TIN or IN
    - The 2-character Country Code
  - inType
    - TIN (Tax identification number), e.g. a Finnish Business ID or tax identification number issued by local tax officials
    - GIIN, identifier issued by the IRS for FATCA reporting
    - IN (Identification number), if a TIN or GIIN is unavailable

Element	Attribute	Type	P/V
DetailsOfIncome			P

- This structure is for details on payments of dividends
- For more information, see [5.7 DetailsOfIncome](#)

Element	Attribute	Type	P/V
ForeignIntermediaries			V

- This structure is for information on the financial intermediaries that transferred the income

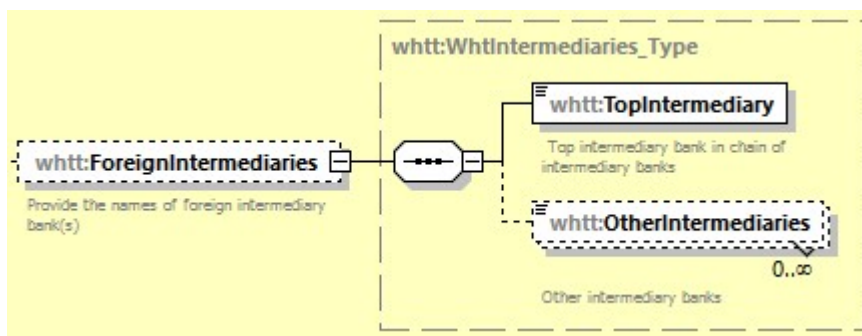

Element	Attribute	Type	P/V
TopIntermediary		string	P

- When the income was paid before 2021: This element is for the name of the first intermediary outside Finland
- When the income was paid 2021 or thereafter: This element is for the name of the intermediary closest to the income beneficiary in the reporter's knowledge

Element	Attribute	Type	P/V
OtherIntermediaries		string	V

- This element is for the names of the other intermediaries in the custody chain, filled in to recurring structures
  - All intermediaries in the reporter's knowledge are reported, regardless of whether the intermediaries are Authorised Intermediaries or Contractual Intermediaries

### 5.5.1.2 Interest

This structure is for interest income.

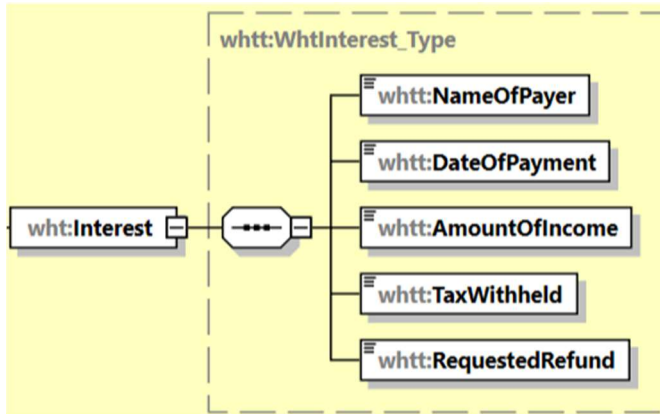

Element	Attribute	Type	P/V
NameOfPayer		string	P

- This element is for the name of the payer of interest

Element	Attribute	Type	P/V
DateOfPayment		Date	P

- This element is for the date when the interest was paid, use the yyyy-mm-dd format

Element	Attribute	Type	P/V
AmountOfIncome		decimal	P

- State the gross amount of the income

Element	Attribute	Type	P/V
TaxWithheld		decimal	P

- This element is for the amount withheld as tax at source

Element	Attribute	Type	P/V
RequestedRefund		decimal	P

- This element is for the amount of refundable tax at source

### 5.5.1.3 Royalties

This structure is for royalty income.

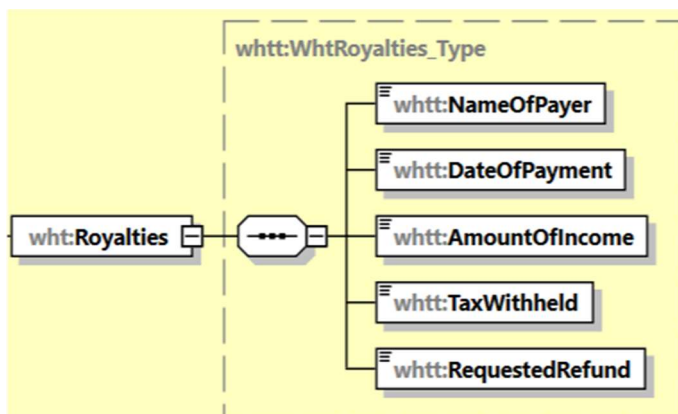

Element	Attribute	Type	P/V
NameOfPayer		string	P

- This element is for the payer's name

Element	Attribute	Type	P/V
DateOfPayment		date	P

- This element is for the payment date of the royalties

Element	Attribute	Type	P/V
AmountOfIncome		decimal	P

- This element is for stating the gross amount of the income

Element	Attribute	Type	P/V
TaxWithheld		decimal	P

- This element is for the amount withheld as tax at source

Element	Attribute	Type	P/V
RequestedRefund		decimal	P

- This element is for the amount of refundable tax at source

## 5.6 BankInfo

This structure is for submitting the applicant's bank information for any subsequent refund payment.

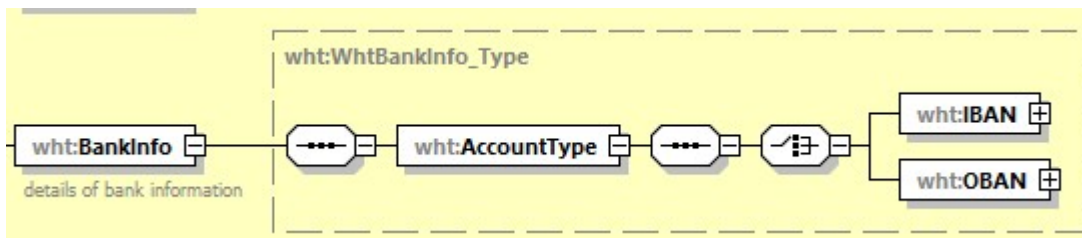

Element	Attribute	Type	P/V
AccountType			P

- Enter the bank account number in IBAN or OBAN format; choose the appropriate structure

### 5.6.1 IBAN

This structure is for bank account information in the IBAN format

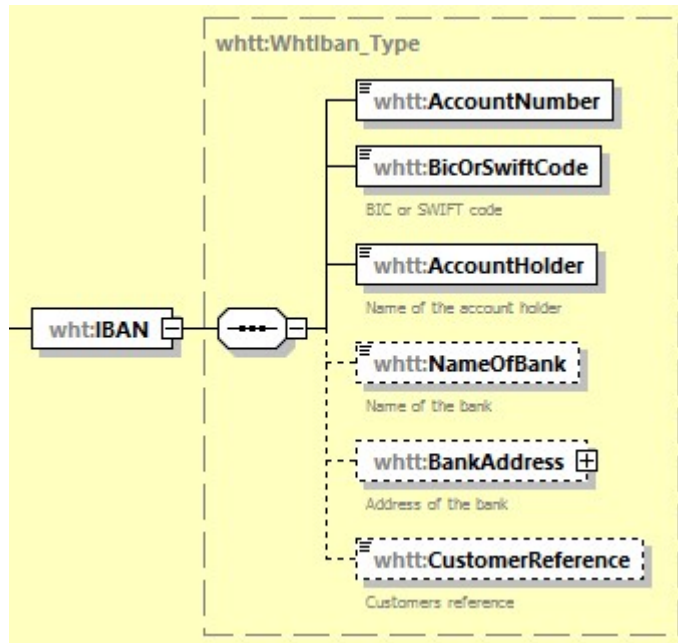

Element	Attribute	Type	P/V
AccountNumber			P

- This element is for the applicant's bank account number in IBAN format
- Ilmoitin makes a check on the format of the IBAN bank acc number

Element	Attribute	Type	P/V
BicOrSwiftCode			P

- This element is for the applicant's bank account number's BIC or SWIFT code
- Ilmoitin makes a check on the format

Element	Attribute	Type	P/V
AccountHolder		string	P

- This element is for the account holder's name – must have exactly the same spelling and format as the bank's IT system has

Element	Attribute	Type	P/V
NameOfBank		string	V

- This element is for the name of the bank

Element	Attribute	Type	P/V
BankAddress			V

- This element is for the bank's address information
- For more information, see [5.4 Address structures](#)

Element	Attribute	Type	P/V
CustomerReference			V

- This element is for the free-text reference code, created by the applicant

### 5.6.2 OBAN

This structure is for bank information in the OBAN format. Only fill in if the applicant does not have bank information in the IBAN format.

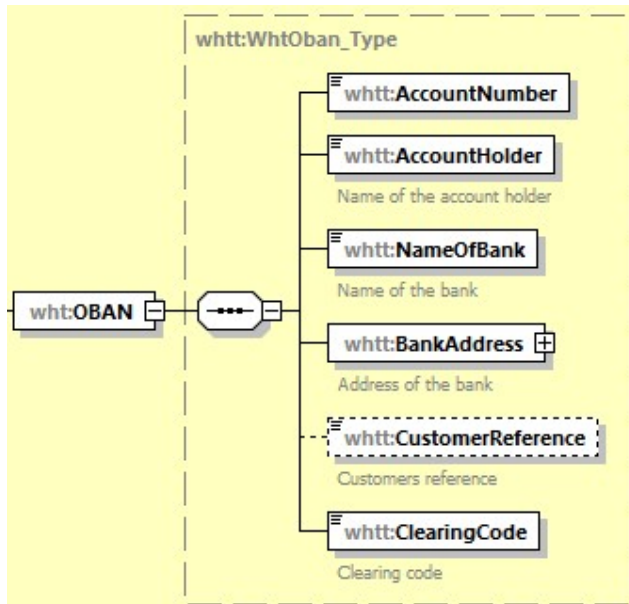

Element	Attribute	Type	P/V
AccountNumber		string	P

- This element is for the applicant's bank account number

Element	Attribute	Type	P/V
AccountHolder		string	P

- This element is for the account holder's name – must have exactly the same spelling and format as the bank's IT system has

Element	Attribute	Type	P/V
NameOfBank		string	P

- This element is for the name of the bank

Element	Attribute	Type	P/V
BankAddress			P

- This element is for the bank's address information
- For more information, see [5.4 Address structures](#)

Element	Attribute	Type	P/V
CustomerReference		string	V

- This element is for the free-text reference code, created by the applicant

Element	Attribute	Type	P/V
ClearingCode		string	P

- This element is for the ClearingCode

## 5.7 DetailsOfIncome

This structure is for details on payments.

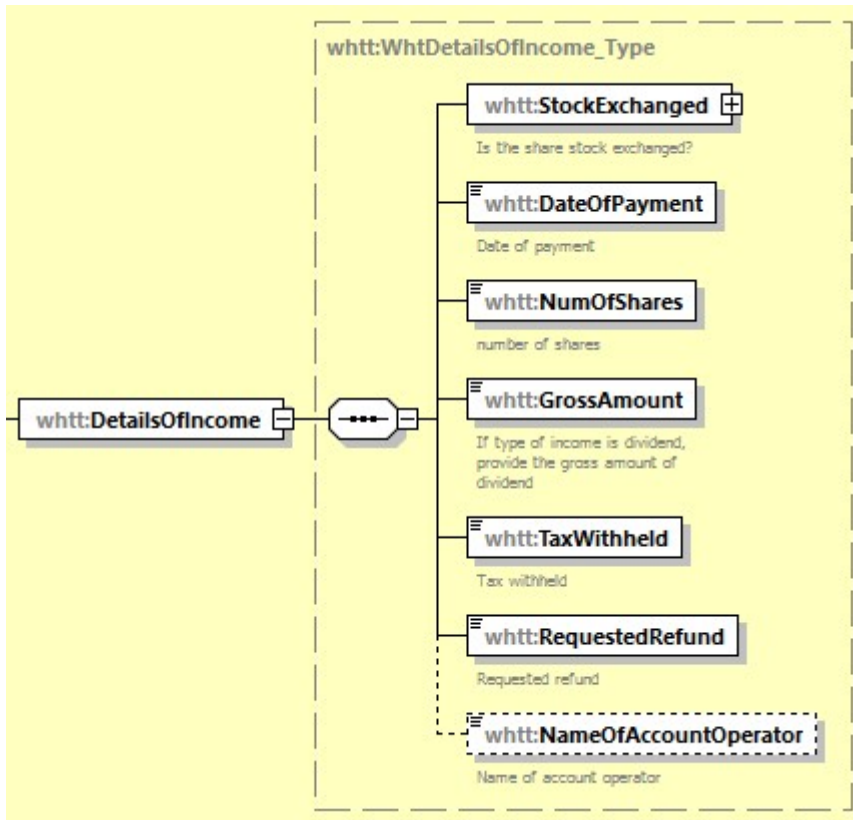

Element	Attribute	Type	P/V
StockExchanged			P

- This structure is for indicating whether the payer is a stock-exchange listed entity (Yes/No)
- For more information, see [5.7.1 StockExchanged](#)

Element	Attribute	Type	P/V
DateOfPayment		date	P

- This element is for the date of the payment

Element	Attribute	Type	P/V
NumOfShares			P

- This element is for filling in an integer to indicate how many shares, on the basis of which the dividend was paid, the beneficial owner holds, if the type of income is "dividends"

Element	Attribute	Type	P/V
GrossAmount		decimal	P

- This element is for stating the gross amount of the income

Element	Attribute	Type	P/V
TaxWithheld		decimal	P

- This element is for the amount withheld as tax at source

Element	Attribute	Type	P/V
RequestedRefund		decimal	P

- This element is for the amount of the requested refund

Element	Attribute	Type	P/V
NameOfAccountOperator		string	V

- This element is for the name of the payer's account operator in Finland

### 5.7.1 StockExchanged

This structure is for indicating whether the payer is a stock-exchange listed entity or a non-listed one; and additionally for an ID code of the payer, and the payer's name.

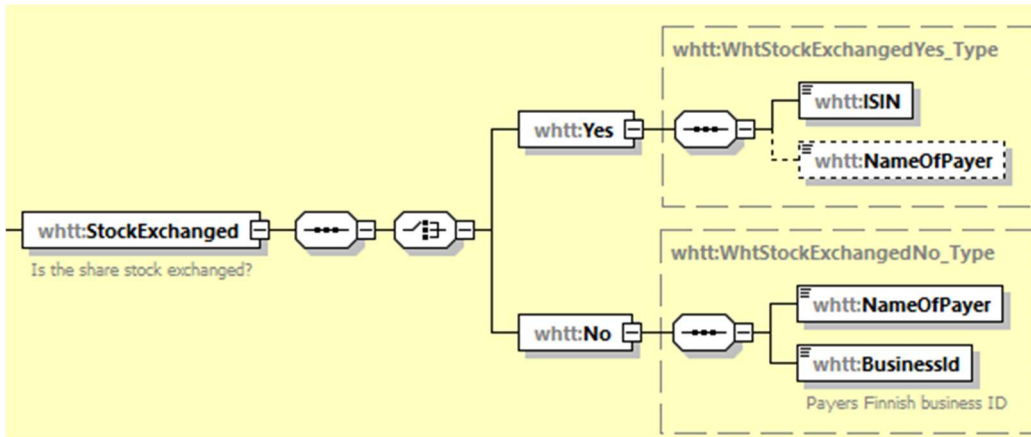

Element	Attribute	Type	P/V
Yes			P

- This element is for stating that the payer is a stock-exchange-listed company

Element	Attribute	Type	P/V
ISIN		string	P

- This element is for the ISIN of a stock-exchange-listed payer
- The system puts up an error message if the ISIN code has a wrong format

Element	Attribute	Type	P/V
NameOfPayer		string	V/P

- This element is for the name of a stock-exchange-listed payer
- Must be reported if the ISIN code is invalid

Element	Attribute	Type	P/V
No			P

- This element is for stating that the payer is a non-listed company

Element	Attribute	Type	P/V
NameOfPayer		string	P

- This element is for the payer's name, if the payer is a non-listed company

Element	Attribute	Type	P/V
BusinessId			P

- This element is for the payer's Finnish Business ID (y-tunnus) if the payer is a non-listed company

## 6 AUTOMATED CHECK PROCESSES RUN BY ILMOITIN

A check process is added	Data element	Description of the check
	All records	<p>Error message: #Aineisto pitää sisällään kiellettyjä merkkejä tai merkkiyhdistelmiä (--,&amp;#, ' tai /*)</p> <p>Translation of error message: #The submitted filing contains unacceptable characters, or unacceptable combinations of characters (--,&amp;#, ' or /*)</p>
	MessageRefId	<p>Ilmoitin.fi checks the format of the Finnish Business ID</p> <p>Error message: #Virheellinen y-tunnus [] elementissä []</p> <p>Translation of error message: #The Business ID in the [] Element [] is wrong</p>
	PublicListedCompany ISIN	<p>The ISIN code must be given, when the answer is "Yes" in the PublicListedCompany element. The format of the ISIN code is also checked.</p> <p>Error message: #ISIN-koodi on ilmoitettava kun PublicListedCompany on true #PublicListedCompany / ISIN-koodi on virheellinen</p> <p>Translation of error message: #ISIN-code must be given when PublicListedCompany is true #PublicListedCompany / ISIN-code is invalid</p>
	NameOfPayer	<p>If the ISIN is incorrect, and if NameOfPayer is missing</p> <p>Error message: #Anna tieto NameOfPayer</p> <p>Translation of error message: #Fill in the NameOfPayer data element</p>
	Individual/TIN, Organisation/TIN, Organisation/UmbrellaFund/MainFund/TIN, Sender/AgentsIN	<p>If the TIN in question is issued by an EU Member State, its validity will be checked</p> <p>Error message: #Virheellinen TIN [] elementissä [] #Virheellinen y-tunnus [] elementissä [] #Virheellinen arvonlisäverotunniste (VAT-numero)</p> <p>Translation of error message: #The TIN in the [] Element [] is wrong #The Business ID in the [] Element [] is wrong #The VAT number in the [] Element [] is wrong</p>
	Organisation/IN, ApplicationID	<p>Ilmoitin checks that the IN or the ApplicationID contains no spaces</p> <p>Error message: #Organisation/IN elementti ei saa sisältää välilyöntejä: [] #Organisation/ApplicationId elementti ei saa sisältää välilyöntejä: []</p>

		<p>#Individual/ApplicationId elementti ei saa sisältää välilyöntejä: []</p> <p>Translation of the error message: #Organisation/IN Element can not contain spaces: [] #Organisation/ApplicationId Element can not contain spaces: [] #Individual/ApplicationID Element can not contain spaces: []</p>
--	--	--

## 7 LIST OF MESSAGES FROM ILMOITIN

A message is added	Data element	Description of the message
	MessageRefID	<p>An error message appears if a report submitted earlier had the same MessageRefID</p> <p>Message from Ilmoitin: #Olet lähettämässä ilmoitusta jo aiemmin käytetyllä MessageRefId:llä, nyt lähetetty sanoma pyyhkii yli kaikki aiemmat samalla MessageRefId:llä lähetetyt ilmoitukset</p> <p>Translation of message: #You are about to send a report with a MessageRefId that has been used previously; if you do that, it will overwrite all the previous report and filings that have this MessageRefId</p>
	BeneficialOwner	<p>The following error message will appear if 'No' was entered in the BeneficialOwner element:</p> <p>Message from Ilmoitin: # Lähdeveron palautusta voi hakea vain tulon tosiasiallinen edunsaaja. Olet vastannut 'ei' kysymykseen 'onko hakija tosiasiallinen edunsaaja vai ei'. Lähetä tarkempi selvitys hakemuksen perusteista Ilmoitin.fi-palvelun Liitteiden lähetys-toiminnallisuuden kautta.</p> <p>Translation of message: #The right to request refund of source tax only belongs to the beneficial owner of the income. You answered 'No' to 'Is the applicant the beneficial owner of the income'. Send more information to explain the reasons for your request via Ilmoitin.fi with its Attachment files feature.</p>
	ISIN	<p>The system puts up an error message if the ISIN code is wrong</p> <p>Message from Ilmoitin: #Tarkista ISIN-koodi, maksajan nimi on pakollinen</p> <p>Translation of message: #Check the ISIN, the payer's name is required</p>

## 8 FURTHER INFORMATION AND LINKS

The XML Schema and example files can be found in the same place as the technical instructions:

[Specifications - Direct data transfers and other e-filings](#)